

# **Book of the Greatness of the Sword**

by  
Luis Pacheco de Narváez

(First Part)

Translation by Tim Rivera

**Note:** Translation to English of some of the technical terminology has mostly followed the English translations of the terms by Mary Dill Curtis (From the Page to the Practice, Ettenhard's *Compendio de los fundamentos*) for the reader's ease of reference. The original Spanish terminology is listed in footnotes at the term's first appearance.

Copyright 2020 by Tim Rivera. Subject to Fair Use in the Copyright Act of the United States of America.

Users may, without further permission, display, save, and print this work for personal, non commercial use, provided that the copyright notice is not severed from the work. Libraries may store this material and non commercially redistribute it to their patrons in electronic or printed form for personal, non commercial use, provided that the copyright notice is not severed from the work.

BOOK  
OF THE GREATNESS  
OF THE SWORD  
IN WHICH ARE DECLARED MANY  
secrets which Commander Geronimo  
de Carranza declared.

*In which each one will be able to give lessons and learn alone,  
without needing to be taught by a master.*

Directed to our lord, Don Felipe III,  
King of the Spains and most of  
the world.

*Composed by Don Luis Pacheco de Narváez, native of  
the city of Baeza, resident of the Grand Canary Island,  
and Sergeant-Major of the island  
of Lanzarote.*

WITH PRIVILEGE

In Madrid, by the heirs of Juan Íñiguez  
de Lequerica, in the year 1600.

*This book has 88 sheets of paper, sold in the street of Santiago.*

*The summary of what this book contains will be found on the  
page before folio 1.*

## Approbation

I have seen this book of the Greatness of the Sword, composed by don Luis Pacheco de Narváez, which touches on arms and their demonstrations, which is the point that was committed to me. I have found everything very curious and of great certainty, because it continues and declares in demonstrative practice the book of the theory of Commander Geronimo de Carranza, the first inventor of this science. In bringing it to light, it advances the common good and advantage, by having much doctrine and erudition, which shows that it has cost its author much work and study, and deserves the mercy of privilege and license to print. In Madrid, June 17, 1599.

*Don Francisco de Herrera y de Saavedra*

## ASSESSMENT

I Pedro Zapata del Marmol, chamber scribe of His Majesty, of those that his council resides in, have faith that the lords of the council, having seen the book entitled Greatness of the Sword, composed by don Luis Pacheco de Narváez, and printed with his license, have appraised each sheet of said book at three-and-a-half *maravedís*.<sup>1</sup> Said book has eighty-eight sheets, which at said price come to three-hundred eight *maravedís*, each volume of said book in paper. They commanded that it be sold at said price, and no more, and that this assessment is placed at the beginning of each one of said books. For the record of the commandment of said lords of the council, I gave the present. Made in the town of Madrid, March 9, 1600.

Pedro Zapata del Marmol

---

<sup>1</sup> A *maravedí* was the smallest unit of monetary value in Spain at the time, equal to 1/34 of a *real*.

To our lord, the King

**T**HE strength of my excuse to dare to dedicate this book to Your Majesty is in two reasonable considerations. The first is knowing that poetic genius dares to dedicate one composed of accents to Virgil, being the most celebrated poet ever, and Marco Barron, who wrote in the Latin tongue, to Marcus Tullius, prince and artificer of it, as well as Paulo Orosio's history to Saint Augustine, who was able to learn all his life. The other is knowing that the alchemists say that there is a Philosopher's Stone, of such marvelous properties and such strange and natural virtue that it will be enough to transmute any metal that it completely touches into gold. The first (having certain knowledge of the clemency of Your Majesty, which is as even-handed as it is powerful) half daring, however knowing that dedicating a book of the sword and propositions of *destreza* to Your Majesty is wanting to bring a log to the mountain,<sup>2</sup> or presuming to teach an eagle to fly. On the second, one comes to a true knowledge that the very fine Philosopher's Stone (with not just one virtue, but innumerable virtues combined) is Your Majesty, and that joining the low cover of this rough work will be enough to change it into gold of inestimable value; that which is undeserving due to being mine will be supplemented by the elevated carats of such a powerful hand and sublime value. I humbly supplicate Your Majesty to receive this small service with the profound humility that I offer; if it is not (as I certainly understand it) as I should do, at least it is all that I could do. By being the fruit of my humble understanding, if it would be protected by such a sovereign power, I would be joyfully obligated again to offer other services to Your Majesty, whose catholic person God keeps for many happy years, as christianity has deserved. From your humble and loyal servant,

Don Luis Pacheco de Narváez

---

<sup>2</sup> A phrase meaning to bring an object to a place which already has an abundance.

## THE KING

**I**T has been related to us that you, don Luis Pacheco de Narváez, native of the city of Baeza, resident of the Grand Canary Island, had composed a book entitled Greatness of the Sword, in which many secrets were declared from the book that Commander Geronimo de Carranza had composed on the philosophy and *destreza*<sup>3</sup> of arms, with its true application in demonstrations, into which you had placed much work, care, and study, seeking the common good, that each one could be better defended. You supplicated us, and we commanded to give you license and privilege to print for ten years, or however long our mercy may be. Seen by those of our council, diligence is made by its decree is stipulated by that the law ultimately made by us on the printing of the books. It was agreed that we should command to give our permit to you for said reason. It seems good to us, for which we give license and faculty, so that for a time of ten years, first following, that run and are counted from the date of my permit, you or the person that you may have, and no other, can print and sell said book, heretofore giving notice, by the original that was seen in our council, which is initialed and signed at the end by Pedro Zapata del Marmol, our council chamber's scribe.

---

3 skill

With that, before it is sold, bring the original before them, so that it is seen whether said impression conforms to it, or bring credit in public form by a censor named by us, having seen and corrected said impression by the original. We command the printer who would print said book, to not print the beginning and the first sheet, nor deliver more than only one original book to the author or a person at whose cost it would be printed, nor to some other person, for the effect of said correction and assessment, until before and first said book is corrected and assessed by those of our council. Being done, and not in another manner, you can print said beginning and first sheet, placing in this our permit and the approbation that said book was made by our mandate, and the assessment and errata, on pain of the penalties contained in the laws and decrees of these kingdoms in which the are stipulated. We command that, during said ten-year term, some person without your license cannot print or sell said book. He who would print and sell it has lost and loses all and whichever books, molds, and equipment that said book would have, and incurs a penalty of five-hundred thousand *maravedís*: one-third for the council, another third for the judge that would sentence him, and the other third for the person that denounced him.

We command those of our council, speaker, and listeners of our audiences, magistrates, constables of our house and court, and chancellors, and to all the administrators, assistants, governors, chief and ordinary magistrates, and whatever other judges and justices, of all cities, villages, and places of our kingdoms and estates, those now as well as those that will be henceforth, which observe and comply with our permit. They do not go against nor pass its tenor and form, nor consent to go nor pass in any manner, under penalty of our mercy, and ten thousand *maravedís* for our council. Dated in Barcelona, June 29, 1599.

I, the king.

By command of our lord, the king.

Don Luis de Salazar

Elegy to don Luis Pacheco de Narváez, in praise of his book, from Bartolomé Cairasco de Figueroa, canon of the holy church of the Canary Islands.<sup>4</sup>

Sonnet to the book of the author, from Serafín Caraiso de Figueroa, warden of the fortress of the Grand Canary Island.

Sonnet to the book and the author, from the licensed Gabriel Gómez de Palacios, ruler of the island of La Palma, one of the Canary Islands.

Sonnet to the author, from the licensed Luis Ortiz de Padilla, ruler of the Canary Island, and lawyer of its royal audience.

Sonnet to the reader, from sergeant-major Liranzo.

Sonnet to the author, from Iván Centellas, resident of the Grand Canary Island.

Sonnet to the author, from Rodrigo Núñez de la Peña, native of the island of Tenerife, one of the Canary Islands.

Sonnet to the reader, from don Pedro de Barros y Montesier.

Sonnet from don Alonso Carrillo de Albornoz.

Sonnet to the author and the book, from don Diego de Pareja Velarde.

Sonnet from Hernondo de Soto, accountant and inspector of the house of Castilla of their Majesty.

In praise of weapons and the author, from don Félix Arias Girón.

---

<sup>4</sup> Elegies and sonnets have not been translated, but their titles have been included.

## PROLOGUE TO THE READER

in which it is proven that the *destreza*  
of arms that is dealt with here  
is a science.

**A**MONG the precepts of natural law, the one whose jurisdiction covers the most and is most generally kept (dear reader), is that of the conservation of one's own nature in all creatures, sentient as well as insentient, rational as well as irrational. This was the reason that Aristotle said that all things that exist desire to be, and they do all things for the conservation of their being, and elsewhere, that all men naturally flee from death and desire a very long life. Since it is already well-known that each animal, however weak it may be, is diligent in defending itself from whatever would want to offend it, and to offend it for its defense. As man, by being more noble than all those together, had more necessity to conserve itself, has been offended many times (which are full of pain and grief) by other men. As the adage says "Man is the wolf of man," an art was necessary that taught how one had to make this defense that served to protect against an enemy as powerful, with as much strength and malice, as man itself, its sworn enemy, not inasmuch as man and its nature since, as Saint Augustine says, all natures have in themselves a peace and natural concord.

In that way, war that man has trumpeted against man doesn't proceed from nature, but from malice and envy. So that this defense is worked better, it sought to be placed in art, which endures for many years. But as malice was strengthened until coming to greater heights than it has ever seen, and the men that had been governed by it were in such discomposure, seeking the same, not just as wolves, but as ferocious tigers, very much like what was said in Proverbs, that as the wicked increase, evil multiplies.<sup>5</sup> This is in as much extreme as the present revolutions testify, greater remedy agreed to greater malice and greater persecution. This defense being so necessary and deserving for man, possessed and tyrannized by doubtful and uncertain opinions, each one wanting to have their own. Our lord God wanted that the damaged spirits of disconcerted and fearful men are restrained, so that the still, peaceful lovers of glorious peace didn't suffer at the hands of the former due to lacking defense, giving opportunity and permitting it to be reduced to science, so that due to its stability and certainty, it did not lack, and always remains like the other sciences. I don't doubt this; rather, I am very certain that he wanted that it happened in this corner of Spain, where the holy faith is professed and kept, and its very holy name is adored and revered. Even though we wanted to understand the men who wanted to tell us they would understand what it was, so that, well instructed in it, we would defend the faith and holy church from the heretical tyrants.

---

5 Proverbs 29:16

They pursued it with which such force and rigor, without ever passing by the thought of a christian man putting hand to sword against another, but as being brothers and sons of the same father, who is Christ. Or accordingly, Saint Peter advises us, a mystic body, whose head is our lord Christ, that we are conserved in sweet peace and amicable concord. As man had to be the one who did this, he was also served that luck fell on Commander Geronimo de Carranza, whose understanding and genius he wanted to favor through wine to attain such a glorious trophy. It is of no less consideration that this was conceded to the worthy and famous city of Seville, fertile mother of admirable and clarified understanding, that we will be able to very justly say that such a mother deserved to have such a son, and such a son deserved to be from such an illustrious mother. This prologue only goes to the field announcing war, being placed in opposition of the incredulous of this true *destreza* being a science. In arriving here, it will be possible that some contrariness is represented, challenging it to a delayed battle with the weapons of ignorance and envy; it will be necessary for us to leave the words of incitement and come to the weapons of arguments, definitions, and conclusions. The godfather that has been chosen is Aristotle, who one will know to defend it well. The first meeting will be to say that this *destreza* is a science, and is proven very clearly by the place of dialectic and rhetoric, which is proving by definition that which is defined. As if we said: It is a rational animal; then it follows that it is a man. Thus we say the definition of science is up to this art, then it is a science.

The antecedent is proven, supposing first the definition of science, that according to Aristotle in the first of his Posterior Analytics, science is a habit that engenders necessary and evident consent by demonstration, which is to say by syllogism or argumentation, that proceeds by a thing's own principles, and itself known, and what are the causes of such a thing. In no other manner can such an effect be made, as the astrologer who says that the eclipse is caused by the interposition of the earth between the sun and the moon. This interposition is its own principle and cause of such an eclipse, and in no other manner can it be caused naturally. This scientific syllogism makes all interposition of the earth between the sun and the moon cause an eclipse; if today or tomorrow such interposition is done, then it follows that it will be an eclipse. That which is naturally infallible is a demonstrative syllogism, which causes science. This supposed, it is proven that this definition fits this art, because it proceeds through such demonstrations, through clauses and manifests, in philosophy as well as geometry, because it deals with natural movements, slow and fast, and with their effects and the natural complexions of men, and their strengths and limbs, which is necessary for the knowledge of wounding and defending. It deals with geometric figures, circles, angles, lines, and Euclidean propositions, which are self-evident principles. Although the principles in this art are not proven here, they are supposed to have already been proven; this doesn't prevent it from being called and being a science, as also music, and other mathematics receive their proven principles in their previous sciences, which are subaltern, as music is to arithmetic, and painting to perspective, and theology to the science that the blessed have, and due to that they cannot cease being sciences.

That's not to say that since this art consists of such different sciences, that it is not a science itself, because although these principles are from various sciences, they all concur in one formal reason, which is to know how to wound and be defended, which is its object. This science pertains to the part of philosophy that consists of action, because philosophy is either speculative, whose only end is obtaining knowledge, or it consists of action, whose end is to work; this action is either internal to man which pertains to the spirit, as is all the moral philosophy (ethical for man to itself, economic for governing ones family and house, and political for governing the republic), or it is external to man, which pertains to governing ones body (such as medicine to heal it, agriculture and hunting to feed it, theater and comedies to ease it, navigation to carry it, wool working to clothe it, and *destreza* to defend it). According to Aristotle, things taken together take the name of the end for which they are ordered. Although that being said is enough for it to be a science, as it is, we don't suppose everything, but go ahead proving it with the definitions of the same science and application of *destreza*. According to the definition in the first of Aristotle's Posterior Analytics, science is a knowledge of a thing by its cause, and it will not happen that what the cause shows has been in any other manner; this definition was approved by all the Greeks and Latins.

There can be no doubt that the science of arms fits this definition, since in itself it has the same knowledge of a thing by its cause: to know that which has to be wounded, and the blow<sup>6</sup> that has to be done to make it, and the instrument with which it has to be done, and the determined proportionate mean<sup>7</sup> to in order do it. Because all that is seen and known through causes and scientific means, and likewise a scientific syllogism is made (having first supposed infallibly that for whatever blow of whatever species<sup>8</sup> that it is, has to have movements of arm and body, or each thing by itself): saying my opponent lifts his arm, making a violent movement,<sup>9</sup> I will say then that he necessarily has to have a natural movement<sup>10</sup> in order to execute some blow, and if he will lift the sword to the obtuse angle,<sup>11</sup> I will know because I have it proven by mathematical demonstration (as will be seen ahead) that establishing myself in right angle,<sup>12</sup> I will reach him to wound without him being able to do the same. This is infallible, because I first know the cause, and from this knowledge, I come to have true notice of the effect that has to happen. If this knowledge would have been by the effect, I would say that I see that my opponent gave me a wound, then there was movement. Since science is a firm knowledge of a thing acquired with a long discourse of days, which never parts from reason, and this knowledge is not altered due to the variety of effects; it can be understood that *destreza* is a science, as the known effects of already known causes are never altered. If science is that whichever cause produces infallible effects, that of *destreza* is knowingly the same, as we know whichever movement that necessarily has to be for *tajo*, *reves*,<sup>13</sup> or thrust, according to the species of each one, effects already known by their causes, in which a syllogism has to be made also certain, saying:

---

6 *herida*

7 *medio proporcionado*

8 This follows Aristotle's classification system of specific forms (species in Latin) of a kind of thing (genus in Latin).

9 *movimiento violento*

10 *movimiento natural*

11 *angulo obtuso*

12 *angulo recto*

13 *Tajo* is a forehand cut, that is, one that is executed from the same side as the sword hand. *Reves* is the a backhand cut.

The blow of *tajo* or *reves* has to consist of four movements, and participation of two angles (as we will declare in its place). Not being preceded by such movements, it will not have said effects; just as there will be no eclipse without having interposition, and vice versa. Finally, in order to be science, it has to deal with universals since, as Aristotle says, there is none that deals with particulars. *Destreza* has to be a science, as it is, since it deals with the universal; this is certain, proven in this manner: the universal technique<sup>14</sup> counters *tajo*, *reves*, and thrust; this is killing all the movements placed in action, and many in potency, at their beginnings as well as their middles and ends, whichever species that they may be. The blows are infallibly composed of movements; these being dead, there will be no blows. Effect is that which touches speculation; that which suits the action will be seen in the discourse of this book. With all that, we make it clear that the *destreza* of arms is truly a science, inasmuch as it teaches a universal impediment, and that this *destreza* is a knowledge and habit that teaches one to give a blow and defend the opponent's blow, and it is that which teaches what man has to be guarded against, and that which has to be done to not be in danger, but not necessarily to wound, as we will demonstrate in the fifth part of this book, where it will be shown scientifically, through evident demonstrations, how a man can be conserved and guarded from his enemies, in the use of the sword.

---

14 *treta*

According to what Geronimo de Carranza alleges, science is nothing other than a scientific exercise of that which one knows. With this, this literary joust is won, and the truth of *destreza* leaves prevailing honorably, whose certainty will never be doubted. Receive this, beloved reader, where what I offer you is of such importance and value for an end as important as your defense and conservation. With a thousand appreciations, I ask and supplicate you, that as this science itself, and the sciences that favor it, are certain and infallible themselves, do not permit (my cause not dealing with it as it deserves, as its first inventor dealt with it) that in its estimation and surrendering the credit which is reason, that it loses something. Take advantage of my desire for benefit and security, which you will reach due to its great certainty, and receive my goodwill that, at a cost of much work that I have suffered, I want no more than to succeed in pleasing you, and understanding that by how much that I owe you, by being my neighbor, whom I have no less obligation to love and seek to conserve than myself, according to the divine precept, I have served you in something.

## EPISTLE OF THE AUTHOR

in response to another of one of his friends, at whose instance  
this book was made, and on what it is based.

**I**F the laws of friendship will not obligate such, and the precepts of them will not force friends to obey them, and this obligation (in me for you) will not be more particular than in others, nor will I take work and load such weight on my shoulders, nor will it be within me to uncover (to my harm) the poor volume of my understanding. But between the wills that are bound with strong tie of friendship, there has to be no repugnance, by having converted both into one. According to that celebrated saying of Tullius that a friend is another me; as your own, I decided to follow your inclination. Although in placing the hand on such high work and material, temerity will seem more inconsiderate than virtuous obedience. I don't know how it will go among those that pursue fiscal facts of foreign works with such strength, as if they were knowingly bad. No other cause is necessary than it not being theirs, and most times they don't understand them, seeming that they are made notably aggrieved by one daring to write, although the verses of don Gaiferos are turning another curious Lancelot and Mesopotonio, Erasmico, who are always occupied in appraising foreign abilities and murmuring of the most excellent, as if it was a rustic swineherd, in all similar to that grand murmurer Zoylo, whose bad-speaking mouth was never open except to speak ill.

Being asked why he had such an abominable custom, I responded, because if I want to do wrong, I can't; because of that, I say that when these detractors want to do some work of erudition, and their ingenuity doesn't have the talent for it, they resort to their tongue, in which, like the serpent, they have the weapons, speaking ill of all, because they are ashamed that others excel more than they. It happens that most of the time they place blame on cases where the guilty (according to their judgment) deserve award and prize. But against all these, I take obeying you as shield and defense, and it suits you to defend this cause and defend me, as you are the one I give my pen to. You ask me for your letter; I send you particular advise and order, which serves you as preceptor or master, so that with it, to yours alone, you can take advantage of the true *destreza* of arms. In order to persuade me to it, you remind me of that saying of the divine Plato, and other Latin authors, that men are not born for only ourselves, nor for only our advantage, and that of Tullius, that says that we owe part of us to our homeland and part to friends, and that one of the principal causes why men were born was to help other men. Asking Leotychidas what the sons of knights should learn when young, he replied: that which is advantageous when they come to the age of manhood. In your estimation, nothing else can advantage them such (other than being virtuous) than the science of arms, as by them we are respected by our friends, feared by our enemies, defending us from them when they want to take our life.

With them we defend the faith, sustain the homeland in quietude, achieve honor, and conserve that which our past left us. Since I commenced writing on this matter, placing in it much care, certifying it to you, some friends with which I have communicated, it is just to make the same with you, advising you how you can conserve life if someone inconsiderately or maliciously wanted to take it from you - causes certain enough that one obeys and serves you, but not without much fear; the caution that you say, I have placed. This is what makes me deserve something, because I have worked ten continuous years, part of them studying, and most in placing it in the state that you see it, because its first inventor, who was Commander Geronimo de Carranza wrote so profoundly on it, as his writings show, but it was on theory, and not on demonstrative practice. As Tullius and Pliny say, there is no art so easy that it can be understood without interpretation and great exercise. Considering that it was a hidden treasure, had by few men, by not understanding or knowing its value with such ease that it did not cost them work. I determined, although making notable aggravation, the greatness and excellence of it and of its author, to manifest and declare that which my understanding was able to perceive, and that which my ingenuity was able to work many times, fatiguing it more than that which I would be able to reach with its flight, because I not only worked by day, but night was not pardoned. With the perseverance of my work and study, experiencing it many times in order to convince me of its certainty, I came to make a small volume, that I kept in my desk.

The times that the military occupations gave me relief, the sword leaving the hand or the arquebus from the shoulder, I spent many times in reading, because that which is a work of our ingenuity is loved, that each time that we see it, we rejoice again; it is an ordinary thing to love that which costs us much work. This came to be understood by some particular gentleman friends, and they importuned me, and it was given, to pass it and see it. Although on my part, I had made the diligence that appeared to me to be enough to understand to be certain of it in writing, I didn't dare to teach it due to a somewhat just fear that I was not adorned with the elegance of rhetoric that suited it to be seen. But in the end, the surplus of friendship defeated my fear, and by the laws of it I asked them (supposing not being able to deny what they asked) that it was seen in secret so that it and I were not reprehended in public, giving the excuse that it was not finished (as in effect it was not). In the end they saw it, and I don't know if friendship was the cause, or something good that they found in it, but it incited them to persuade me with many truths, and I continued it until I was able to bring it to light. Although this was my first intent, in the middle of the course I feared putting eyes on the consideration that I dared much and offered to suffer more. This fear increased, coming and considering that if biting tongues and envious and harmful intentions pursued its first author (being the principal trunk), that not having thrown the roots of his authority to such depths, in some manner they prevailed against him, that some envious wind wilted this small sprout for some time, because the false opinions usually have authority in some intervals, although in the end the truth prevails.

I placed all this in front of them, in order to excuse me from their demand, being content to have it in draft for only my pleasure, without placing it to be judged by many that are deprived of virtuous things. In the end, their persuasions were more capable on me than the excuses that I gave them, and my fear gave them spirit, and they reduced my tepidity to confidence, from which returning to pass with attention and communicating with learned persons, it would be able to go public. What they convinced me with the most was in saying that it would be advantageous to many (which is my particular zeal), serving the very daring as a bridle, so that they deal with the arms from here on with prudence, and the fearful as spurs, as it is certain that the spirit is augmented with the art. This was the most sufficient cause that defeated my will, to follow theirs, and with much work and study, I came to reduce it to demonstrative practice, with demonstrations so clear (in my opinion, and many others) that any understanding will be quiet, and the spirits will be so appeased that none will perturb them, without being fatigued as much as mine, by knowing in the state in which it has to remain, after having given the blow or formed the parry,<sup>15</sup> for all to be without danger. With all this, I was not determined to publish it, remembering that saying of Ovid, as he says that the truth engenders hate and enmity; as my principal intent was to declare truths, and using the strength of them to destroy the false opinions and liars that ravage and unsettle the judgment, making the false appear true, and the doubtful certain, and the notably harmful advantageous.

---

15 *reparo*

I distrusted that my work had the due acceptance that it deserves, because those who follow inconsiderately are such that they throw themselves into the dangerous gulf of vulgar opinions and deceit, like it was a safe port, following their opinion in all, which most of the time is the cause of giving the cost of their perdition, in notable danger. Although each day they suffer and see themselves through experience, which their malice doesn't allow them to know. The tie is so strong that, in their opinion and inclination, some will leave it with difficulty and rather die ignorant than live disillusioned, due to the difficulty of being persuaded of that which our will doesn't want. The harm that comes from here is having one's understanding blinded, so that they cease understanding, and that one who will navigate through the dangerous sea of *destreza* without the governing and reason of science will be flooded in any gulf, and will be lost in any shallows. As the wise say, one who loves danger will die from it. Being just, they considered that things do not have to be esteemed by how they appear from outside, because the exterior deceives most of the time – the gold with which they are gilded being false, and the copper that they are composed of being low. The man who wants to succeed does not have to do that which his appetite requires, nor that which his inclination brings, but that which reason will advise. Having in memory that which Casiodoro<sup>16</sup> says in the third epistle, that science purifies customs and teaches one to live well, so that at all points they were placed in its hands, offering obedience to the universal lord of one who truly seeks to know.

---

16 Casiodoro de Reina

As Quintilian says, it is not a shameful thing for a man to confess that he doesn't know; doing this and seeking it on their part, they will make use of its smoothness, which is such that the palate of those that dispassionately please it is sweeter and smoother than syrup. They will be adorned with temperance in their inconsiderate movements, which is wisely changing advice when they err, since the heart of man is moved and persuaded more with an example than with a million words, which the common sentence of rhetoric affirms. I don't want to spend more time on these; rather, I want to petition those who have professed the ordinary *destreza* from a young age to tell me the work that they have suffered for it, the danger, displeasure, suspicions, shocks, fears, uneasiness, wounds, and deaths they have suffered and seen those that were more resourceful in their techniques to suffer, by merely trusting in them, mostly given by rustic men, without any use in *destreza*. So what is this? Whose fault is this? Will we put it on the *destreza* that they profess, or on those who are the professors? On them, it is not just, because in many, their spirits are so valorous that they would easily undertake heroic things and be able to be conquerors by being knowledgeable in the truth; most times they are adventurously defeated and dead. It only remains to them (however much) time to repent their crazy confidence. So we place it on the vulgar *destreza*, as it is founded without the fundamentals of science. Through this, although all men want to be *diestros*,<sup>17</sup> they cannot achieve it perfectly, because it is the cause of searching for it through such uncertain and dark paths, before they will put their eyes on the murkiness of the danger, that they leave to light with that which they intend.

---

17 skilled swordsmen

But I don't know what type of confidence animates me, as they have to take note of the good that will be left in the one and studied in the other. In such manner, they have to study this true *destreza*, which brings well-known advantages in spirit as well as the other nations, and these confessed by themselves, have also come to know to scientifically exercise this true *destreza*. Your letter asks much of me, with respect to the small volume of my understanding, but considering the many obligations that I have to keep, I decided (though not without fear) to begin it. With this, I will compile that which I desire with such truths, which is to serve you, and more on this, which has to be for guarding and conserving your life. If in that, I will also not know to declare how I would like, or you would like, understand that it is not lack of will, but rather it seems to me to be an ordinary thing in man (according to what Tullius says) to not be able to properly explain with words that which they feel or know. Being so, forgive the defects that my pen will make. In recompense for these, I offer my will, since, as Erasmus says, that which is offered with it must be acknowledged.

SUMMARY OF WHAT  
THIS BOOK CONTAINS  
in each of the five parts into which it is divided.

*In the First*

**P**ROLOGUE to the reader, in which it is proven that the *destreza* of arms that is dealt with here is a science.  
An epistle to a friend of the author, at whose instance the book was made.

The foundations of the true <i>destreza</i> , fol.	1
The elements and signs in the exterior, and composure in the members that one who would profess it has to have for more perfection. It is an important point for the captains that want to lift people, folio	6
The interior elements one has to make use of; it contains five important points, which are, fol.	12
Understanding, and its great importance, fol.	13
Ingenuity, and that which is valued in <i>destreza</i> , fol.	14
Memory, and its office, fol.	16
Prudence, and that which is its charge, fol.	18
Spirit, and its value, fol.	19
What elements the master who would teach this <i>destreza</i> has to have; this point is important to the disciple that would learn it, supposing that one wants to learn from a master, fol.	22
What elements the disciple has to have, who such master has to teach, and some advice is given to the master, how he has to teach it, and at what time, and what he has to exercise first, fol.	27
A judgment between the two <i>destezas</i> , true and false, where the truth and certainty of the one, and the uncertainty and falsehood of the other, are proven, fol.	32

## *In the Second*

The precepts that one who wants to be a *diestro* has to keep to, in which it is taught how one has to set their feet, which is the first foundation, and how one has to have the arm in order to be well-profiled, all in demonstrations. In this point, it is advised from where each blow of the ordinary *destreza* is formed, and how one has to take the sword, fol. 36

How one has to choose the mean of proportion<sup>18</sup> with equal and unequal swords, which is of much importance, fol. 51, 53, 55

A demonstration which manifests how one has to step in *destreza* in order to be safe, fol. 56

Another demonstration, where the rectilinear angles are manifest, and particular things of importance are advised, for wounding as well as being defended, fol. 58

Particular and important advise on the steps,<sup>19</sup> and what is a simple step and double step, the feet that each one has to have, and what length the foot has to be, which is of much consideration, fol. 66, 67

A demonstration which manifests the three circles that the arm makes, corresponding to its joints, and each one for what blow, and which will defeat which, fol. 69

Another demonstration which advises the three blows that there are, which are named the blow of whole circle, half circle, and quarter circle, and which will defeat, fol. 71

Another demonstration of the chord and the arc, which is the same as circular movement and straight movement, where it is proven which wounds more quickly, fol. 72.

Another very important demonstration which can be considered in *destreza*, where it is shown how the right angle reaches more than any other, fol. 75

A particular demonstration of four lines, which are straight line, parallel lines, circular line, and mixed line, fol. 78

---

18 *medio de proporción*

19 *compases*

A declaration in which it is advised what a blow is, and what it is composed of, and what is a blow before time, in time, and after time, fol. 84

### *Third Part*

The most common techniques that are practiced and used in the ordinary *destreza* are placed in this part, which are, fol. 88

Crossing the sword in front of the chest, fol. 93

Technique of inviting,<sup>20</sup> fol. 97

Technique of testing,<sup>21</sup> fol. 101

Technique of punching thrust,<sup>22</sup> fol. 105

Most famous technique, which they call *arrebatar*,<sup>23</sup> fol. 107

Technique of giving a blow on the sword,<sup>24</sup> fol. 112

Terrifying technique that they call ripping *tajo*,<sup>25</sup> and the certain remedies against all them, all in demonstrations, fol. 116

Advise on the theory of the *brazal*,<sup>26</sup> and in how many parts it is done, and the slap,<sup>27</sup> and thrust to the foot, and to the elbow, and the remedy for all them, fol. 121

Particular advise on which arm – dagger, cloak, buckler, and shield<sup>28</sup> – will be able to defend best, fol. 126

More advise of the proportionate mean, what it is, and its importance, fol. 131

---

20 *llamar*

21 *tentado*

22 *estocada de puño*

23 beating away

24 *golpe en la espada*

25 *tajo rompido*

26 bracer

27 *manotada*

28 *rodela*

### *Fourth Part*

The particulars of the true *destreza* are placed in the fourth part in demonstrations, blows of first intention as well as second, *tajos*, *reveses*, thrusts and parries, and the manner that Turks establish themselves, how one has to wound them, fol. 135

### *Fifth Part*

In the fifth and last part, eight very important points are placed, which are, fol. 243

The exercise that the *diestro* has to have, how one has to exercise, with what sword, and how to exercise the arms, without removing the cloak, sword, nor dagger, and why it is very important, fol. 244

The reason that one has to have to fight, and how without having much, one has to not put hand to sword, which is a point of much doctrine and importance, fol. 248

A very particular rule, of great importance and advantage, how the complexion of a man will be known by their physiognomy, with which one will have notice and knowledge if one will be spirited or not, partitioning the year, and the day, and the age of a man, in order to know at what time one is most valiant, and how one has to wound each one, according to the time, age, and complexion, and advised with which of the men – tall, short, or medium – one will be able to be defended best, fol. 252

How the four cardinal movements have to be known, which are violent movement, natural movement, offline lateral movement,<sup>29</sup> and mixed movement,<sup>30</sup> fol. 266

The grand importance of touch,<sup>31</sup> and how without it, the defense of the *diestro* will not be certain, nor will it be able to work universally, with respect to killing the movements with the *atajo*, fol. 272

---

29 *movimiento remisó*

30 *movimiento mixto*

31 *tacto*

How important the conservation of breath is to the *diestro*, and how in lacking it, one cannot overcome not be defended, and how it has to be conserved, fol. 272

The admirable effects of the universal rule, where it will be seen what it is, and what makes use of it, and how there is no particular blow that is not inferior to it, nor a movement that it doesn't kill. A doubt is placed and declared, with which one can fight however many men, which is a point worthy of being known, fol. 276

Five paths by which the *diestro* has to walk, for the blows of first intention as well as second, whether circular for *tajo* and *reves*, or for thrust, and the quantity that each one has to have, and how much each has to part from the line of the diameter, and the difference that there is between the steps, simple as well as composed, is advised, which is a point that, without understanding it very well and exercising it many times, one will not be able to be a *diestro*, fol. 285

The graduation of the sword, where its strength and weakness is manifested by numbers, and how in order to subject the opponent's sword, one has to have advantage of greater number, this is as important as the above, concluding with the universal in theory as well as in practice, placed in demonstrations, and in all the discourse of the book, many examples and sentences deserving of being read, and benefits to be imitated, fol. 291

## THE FUNDAMENTALS ON WHICH THE TRUE DESTREZA IS FOUNDED

**S**INCE having given beginning to obeying you, it is necessary that you first know the elements of this true *destreza* that you want to profess - the strong fundamentals on which it is founded, its lordship and greatness, because it is a just thing that before the will deliberately wants something, the understanding (in whose charge is the examination of all) examines and sees if it suits or not. Many times, in not doing this, men learn things that are the cause of their perdition, taking them (as they say) without thought, having to note the business that they want to begin. At their beginnings, the ends that they can have are looked upon with prudence; they don't leave after that to weigh that those without this diligence and these discerning considerations usually begin and end, nor do they give caution in returning to undo. Because however important a business, it suits much more to examine and look at the means that need to be placed in order to reach it, in order to be certain in it, because a man being deceived in a concept, misunderstanding a verse, not explaining a law well, and similar things, have remedy in returning to look at them, or lose advice.

Being deceived and erring in business as important as knowing how to be defended from the cautions and deceits of one's opponent is an error that has no amendment, and no less cost than one's life, or endangering it. Many have seen this through experience in their harm and perdition; in particular the young who, due to their young age, don't have the capacity to seek the means with which one achieves defense of their life, honor, and home, which is the true *destreza* that we deal with. By being a type of virtue which is reached with much age, and long experience, or much understanding and great prudence.

The first on which this true *destreza* is founded.

The first and most principal part that makes it so illustrious and valuable is being certain and true, having its own truth like the other sciences, due to its demonstrations being so evident and infallible. The name of truth is of such majesty and greatness that in saying that something is it, there is no more to say, nor greater appreciation than placing it, because just as the truth itself is firm and certain, what is founded and promoted in it is certain and firm as well, because the certainty of the effect consists in the certainty of the cause from which it proceeds, but when the beginning or cause is false and uncertain, the effect that will proceed from it has to be false and uncertain. On this truth, Marcus Tullius says that its strength is so great that by itself, without any help, it defends itself from the ambushes of those who maliciously want to conceal it. Because *destreza* has the truth, it has the same effect and always leaves victorious. Truth is that which rules the heavens, lights the earth, sustains justice, governs the republic, confirms what is certain, and clarifies what is doubtful;

it is the center, where all things rest, the north, by which all the world is ruled, and white, where all must travel. Because *destreza* reaches and makes use of this truth, as much as it is possible, it has the same effects, because it rules men, showing them how they have to seek their conservation and defense by certain paths. It illuminates understanding and satisfies it with its evident demonstrations, sustains man and defends ones life and honor when the enemy wants to take it, which is one of its particular effects. It governs this science, advising how and where it has to be sought, confirms in certainty that which was opinion until now, clarifies that which is not certain with its presence, because a contrary with another is known better. It is the center where all the aficionados of men inclined to arms want to rest. It is the north by which all have to rule if they want to succeed. We conclude with the saying of the very wise Socrates, in the first book *De Ira*,<sup>32</sup> which says that there is no virtue that the gods reward more willingly than truth, nor a vice that they punish more harshly than a lie. *Destreza* also has these two effects in both, because it rewards men who profess it and deal with it scientifically, giving them success in the end so that they profess it; to those that follow the opposite, it brings the rigorous punishment of danger. As it is certain that that which is not known is not loved, that said, it is well-known what truth is, and the *destreza* which makes use of it, and how great its virtue and excellence, which is well-proven. We move forward.

Effects of  
*destreza*.

---

<sup>32</sup> *De Ira* (On Anger) is by Seneca, rather than Socrates.

Second part  
on which  
*destreza* is  
founded.

The other part that it has, which is no less excellent, is that this marvelous edifice of *destreza* is founded on such strong fundamentals that neither will the rigor of time consume it, nor will it ever age, nor will it lose one point from its being, because whichever part that you see, you will find that it is supported by the solid walls of the sciences, which help it with the truth that each one has by itself, and favor it with their certainty, and make it stronger, adding strength to strength. This is such that if mathematics itself has certainty and truth, *destreza* is shown by it, and strengthens it with its demonstrations. If arithmetic itself has truth and certainty, that *destreza* is accompanied by it, because it deals with account and reason. If natural philosophy uncovers and manifests many secrets to us, the same declares those that *destreza* has. Since its first inventor, in the speculation of each one, raised the cords of his understanding to such a point that the most taken advantage of in him have been admired in the order of the subalternation of the ancient sciences with the newly invented. On *destreza*, for which a book was made so curious and appealing, as profound in sentences as the rest are lacking, I remit it to you, where you will be able, at your pleasure, to fill your hands with your desire. The lordship and greatness that it has is such that a man who will soldier under its protection will have dominion and power over others' wills. Since there is truly no greater key to open them than a wise man, and they receive it, because the science that professes is the cause that all respect, love, and favor it, but in no part is it found strange.

The lordship  
that this  
*destreza* has.

As Diogenes says: the wise man is a citizen of the whole world, and he lacks nothing in any part; with it, he has safe passage and a letter of recommendation for all. Aristippus confirms that in the response that he gave to those that asked him what the difference was between a wise man and a fool, saying: Send them both naked among strange people, and you will see the difference that there is. Meaning that the wise man, although he is naked in a strange land, brings with him the treasure of his wisdom, because of which he will not lack friends, and the naked fool will only find those who laugh at him. Already one is in danger of dying of hunger, because as the works of man uncover the greatness of his genius, and science is very high, and according to Aristotle, good is the best thing in the world because all desire it. Being as it is the object of our will, where it wants a scientific man to go surely, because he has provision for all his life, and the fool loses this and many other things that would be able to be said for this proposition. We will conclude this point with one from Socrates; this learned man says that science is the only good, and conversely, ignorance is the only evil. The reason is because ignorance is the cause of all the ills that are committed, and science of all the good that is done. Because that which is praised, wanting to give praise to it is taking it away. The rest that is lacking in this, I remit to your understanding.

THE EXTERIOR ELEMENTS AND SIGNS,  
and composure in the limbs that one who will have to  
profess this true *destreza* has to have for more  
perfection.

**A**S we have said the most excellent parts, fundamentals, and greatness of this science, and it has been proven with reasons founded in reason, it will be just that you know those that one who want to profess it has to have. So that you are not deceived, nor anyone is deceived in understanding, as a tree without a lord will be able to take advantage of its fruit, and it is necessary that there is much consideration in this, and that no one is positioned to learn science who doesn't have his ingenuity disposed, and in particular to this, where such elements are required. Because someone who is known will have doubt, being as human presumption is such that one who had less elements will imagine themselves a Solomon in wisdom, an Aristotle in liveliness of ingenuity, a Caesar in spirit, and a Hector in strength, and will dare to think to run rings around one who will make more use of this. I want to enumerate and give the elements that have to be used in the exterior, and the signs with which one will be able to know, so that none are deceived – those that will want to learn, as well as those that will want to teach.

The men that the ancient Romans chose for war, with the desire that they had to be conquerors, and subject the world, and lord over it, searched for them with such caution, and the captains received them with such modesty, as if each one was for captain, or in each one by himself would bring the end of the desired victory. This was a very just consideration, because the congregation of an army is like the composition of an antidote, which is composed and formed of various things, and none by itself causes the effect that it's composed for, but all together. In this way, many strengths are joined from many men, and a potency is affirmed by these strengths, which all together - men, strengths, and potency - cause the effect for which they are ordained, which is to defeat the enemy and conquer the field from the opponent. Because of that, they searched for them, such that each one helped with his virtue and effort, without some having harmed and frightened the others. Because according to Vegetius in *De Re Militari*, it doesn't suit that any soldier is received in the squadron without his spirit and effort considered first, as otherwise it will result in harm to one who will trust it. We have a real-life example of this in what Julius Caesar did, having to come to speak with Ariovistus, his enemy and enemy of the Roman republic, on the condition that he only came with the cavalry. So he removed the horses from the Gauls (which were the French) in whom he didn't have much confidence, and commanded them to be mounted by the best and most valiant soldiers of the tenth legion, which had his complete satisfaction, due to the long knowledge that he had of their effort and valor. In that, Titus Livius advised with great appreciation: Guard well, Captains, that you don't have in your field more strangers than your own soldiers. Here he calls strangers those that are not known.

Vegetius, *De  
Re Militari*

Another real-life example was given to us by Agesilaus, king and captain of Sparta, having made alliance and brotherhood of arms with other provinces close to his, in order to defeat and offend his enemies. Hearing that his companions were complaining that he always had them at war, especially because they were many, and the Spartans were few. Because of that, wanting to show them the opposite, that the Spartans were more, even though less in number, Agesilaus commanded the companions that firstly the potters and singers left, then the smiths, cobblers, masons, and other craftsmen. In this manner, almost all the companions had parted, but the none of the Spartans had parted, because those of this nation who were warriors were prohibited from exercising or learning art or occupation where one had to be seated. The king told them: "Look here, men, how many more we are than you," showing that nothing goes in a great number of people leaving to war, but in being strong and known, and over all, very exercised. If the opinion of the philosopher Antisthenes had to be admitted, he says that it is better to fight with good, although they are few, against many bad, than with many bad against few good. Not trusting in low men, nor mechanical artisans, nor men of little honor, but in knights and men known for virtue and effort. The Mapuche did this on their own, and with no less caution, as in the young being of age to command arms, they exercised with them, and being sufficient, they were received for war;

Among the Spartans, no soldier could be a mechanical craftsman.

Among the Mapuche, a soldier could not be a craftsman.

not being so, they were deprived of the use of them, and sent to the fields to farm, being charged with and subject to serving those received to the military art. It is very different from that which is practiced in our time, as we see that if whichever person will want to be a soldier, whatever type that he may be, a captain receives him under his banner, only to increase numbers. From this it happens many times, in the moment of truth (which is where the valor of each one is shown), that the captain is lost, and they were saved, because as the contemptible don't work to have honor, nor feel that it is an affront, nor believe fleeing is shameful. They are easily welcomed to it, as a safe port for their cowardice, leaving the poor captain on the gallows, paying the just punishment owed by the little caution that he had in seeking one who helped him with valor and effort. They are judged as incredibly lucky, in being able to bring the news of what happened. Faithfully, truly, if he would have had the custom that the Spartans had, that few would flee, because among this nation, all those who fled battle were killed afterward by their captains, because among them, it was worse to flee than to die. Because of this, Erasmus said very well that it is best for the captain in war to see people come with him, and that such is what his enemy has, that he doesn't count the number, because one does not trust many soldiers, nor fear the few, because victory proceeds and is always reached by the good and not the many. This truth lets us understand, with enough approbation and disillusionment, what happened to that famous captain and leader Gideon, as going to fight against the Midianites, brought an army of thirty-two thousand soldiers.

Condition of  
the low and  
contemptible.

Custom  
among the  
Spartans with  
the soldiers  
who flee from  
battle.

God commanded him to not bring cowardly people, and those who feared battle were allowed to return freely. This license given, and this general faction made, twenty-two thousand made use of it and returned, with only ten thousand remaining. After, he returned to command him to choose the most valiant, and dispatch the others, giving him a sufficient sign to be certain to know them, which was that he brought them to the waters, and that those that drank by hand, taking the water in it, he was to choose and take only those to battle; those that drank by sipping, he dispatched and dismissed. This diligence made, only three-hundred soldiers remained, with which he entered into battle with the opponents and defeated them. The same will happen to our captains if, in receiving or choosing soldiers, it was with the diligence of bringing them to the waters of some small danger, to prove their valor and spirit. But wonder at this consideration, that if a captain, or before being one, is offered some quarrel (which I say quarrel) patrolling the street of his lady, seeks to bring friends with him, which accompany him and guard his back; for this, they are valiant, spirited, and determined, with the case not being of much importance, and I know that when they go to fight for law, king, and republic, and the rest for their reputation, that they are content in bringing one-hundred Benitillos. Although it is true that one who brings them as soldiers, whose value in that is good, deserves (serving his king and lord) all the mercy that can be given, neither priding oneself in sitting them at his table, nor giving them his side, because they don't deserve either one.

Having to understand that one who lacks valor in order to deserve this, will not have to free it from the danger and battle that will be offered to him. It will be much better to bring five-hundred honored soldiers than a great number of these Antoñuelos, so that when they will undertake some arduous and difficult enterprise and conquer it, it is a greater honor, not bringing trivial people that serve as an affront to him; such a captain will be with five-hundred men as he is with two hundred. It is without such great reason that a swineherd, or others similar, are given the investment and honorable habit and name of soldier, as it is properly of kings and noble men. A captain will want to make people and know the men in whom he has to trust, and the master has to teach the disciples and see if each one is suited for this science, so that the one is not seen in danger, and the other is not tired without advantage, nor does the disciple spend the time. They seek men with these signs, who are strong and vigorous, according to that which is affirmed by serious authors, ancient as well as modern.

## THE EXTERIOR ELEMENTS

**F**IRSTLY, they have to have the head erect, the eyes lively and alert, the voice thick, the chest high, the shoulders wide, the arms round, the fingers strong, the abdomen lean, the thighs thick and sinewy, the legs in good proportion, the feet lean, medium stature, and the gait composed, of tempered province, hungry for honor and wealth. These elements are certain and very necessary for a man that would profess the arms, and there is no doubt in it. Although many have dealt with them, it has been all together, without giving some cause or reason, because they have to be this way and no other. Because of this, the best that I will be able, I will declare them, being helped by serious authors, whose authority is the greatest proof of it.

The head.

For the head, it suits that it is proportionate, due to being the principal member and where the senses are. It is the watchtower where one sees how they have to be governed in their movements. It has to be equal so that it communicates its virtue equally to all the other members, to each in its own way; to each member according to its office, and that this proposition declines to greater, rather than to lesser. This helps to understand well the opinion of Hippocrates, which says that a small head is bad, as well as a narrow chest. Galen affirms that a small head is a sign of poor understanding and a badly-formed brain. As such, having a well-shaped head argues for having a good brain, good understanding, and much prudence. According to the problem that Aristotle gives, asking what is the cause for man being the most prudent animal of all, one responds that because one has a smaller head with respect to the body, that one who would have a more proportionate head would be more prudent.

This is the same as the opinion of Plato, that what is medium, neither large nor small, but in the means is the best, because one who would have a small head will be angry and fearful; the reason is that a small head is inflamed quickly and heats up to the point that the blood and spirit close to the heart (where anger originates) are inflamed. From this proceeds the ability to discern things certainly and clearly, and continuously doubt them. From this doubt, proceeds fear, because one cannot work their operations, which are imagining, understanding, and remembering; lacking this, one lacks confidence, and this lost, the spirit cannot remain, whose lack causes one to lose their life, or at least their honor. Plato

The hair has to be raised or curled, because according to the opinion of the authors which I follow, boldness proceeds from the hot and dry complexion, as fear is from the cold and wet complexion. Having curly hair, generally one is bold, because it proceeds, for the most part, from heat and dryness; having straight hair proceeds from coldness and wetness. Because of this, a man that has curly hair will generally be bold and choleric, and otherwise fearful and with a phlegmatic complexion. The hair.

The forehead being smooth and without wrinkles signifies a man who moves as he wills and seeks questions, by being a hot and dry complexion. This heat and dryness makes the forehead hard and tight, and without wrinkles. One who will have many will be of a cold and wet complexion. Because of this, being in the mean is best, as well as in the width, which should be neither too wide nor narrow in the extreme. The forehead.

The eyebrows.           The eyebrows neither very long nor very arched, because one who has them very long will be arrogant and shameless, because it proceeds from great heat of complexion, from which proceeds arrogance. Thus in the length of the eyebrows, and their abundance, the saying can almost always be noted and certain.

The eyes.                The eyes give indication and show most times what is in the heart, as they are their windows, through which the type of things that are desired or abhorred enter. Their heat argues for the temperance of the brain and shows the accelerated or lazy impetus. Having them very lively shows having much heat, and amazingly, those who have grey or somber eyes cease being spirited and bold. Having sad eyes is a certain sign of lacking heat, which is that which makes a man spirited, bold, and determined. Because there are many differences in the eyes, each one important, we will say one point on each one of them. Thus, having very sunken, deep, or concave eyes demonstrates that a man is a traitor, because according to many authors, having deep and small eyes prevents material poverty; it also denotes being of melancholy complexion. As the effect of this is making a man melancholy and at the same time fearful, and the nature of this humor, engendered by cauterization of cholera, is making a man bad. Because of this, they say that one will be a traitor, and fearful, because treason done in this profession of arms is not done, but forced by vile fear and notorious cowardice. Having bulging eyes is a sign of a man being a shameless speaker. It is the reason that, as the type of everything enters through them (as it is said), having wide-set eyes, they receive many types of various visible things;

as understanding is discursive, one to one, it does not determine all together in a short time, as apprehending one and another, and many, one cannot judge them and speak of them with good judgment. Having very large eyes is a vice and a certain sign that one will be slothful, because it signifies a teeming mass of phlegmatic material, from which proceeds a cold and wet complexion, and from this, sloth and fear. Having large pupils gives enough of a sign of a man being slothful and of little ingenuity, because of being a cold and wet complexion. One who will have it very black is certain to be timid, because fear proceeds from coldness of complexion, as we have said; the black pupil signifies a cold and wet complexion. In conclusion, seeing a man that has sad eyes, without any liveliness in them, it is certain that he will not make use of the heat that suffices to give him liveliness, promptness, and spirit. On the contrary, the best are those that are mixed black and white, because such are of good nature and temperate complexion, from which proceeds temperance of customs, and following reason in all, which will be choleric phlegmatics, who know to wait with tranquility when it suits and attack when it is necessary. The voice should be large and thick, not too much, but with some gravity, because such denotes a lively man and spirit, according to the opinion of Galen, which says that a large and somewhat rough voice indicates much heat. Aristotle is of this opinion, by which one has to avoid men that will have womanly and childish speech, which is ordinarily thin and skinny;

Understanding is discursive, and judges each thing by itself, not all together.

What sloth and fear proceed from.

A man that has sad eyes will not be valiant.

The voice.

Galen  
Aristotle

Good and true  
saying.

it will be seen without any doubt that such are mostly phlegmatic and of little spirit, because one who is similar to some animal in something will also be similar in complexion and participate in similar customs to such animal. It is well-known that woman is of little spirit; he who is similar to her in something will be the same. Because of this, a serious man said of our Spain: abhor the body of a healthy man that has sickly or womanly speech, and avoid a woman with manly speech, because in the one, nature worked to make a man, and for some reason a woman emerged, and the other was for a woman, and a man emerged, because ordinarily they attend to those inclinations, the one manly and the other womanly. Finally, the voice has to be a little thick, and this cannot be so except in those of great heat and strong virtue; however much more it would be, one will push more air out of the channel of the lung, which is from where the thick voice proceeds according to Galen and other authors, who all affirm that a large voice proceeds from a great quantity of air that is moved from the lung to the throat, which proceeds from the heat of nature, as is said. One having a large voice proceeds from great heat of the lung and heart, from which we will come to understand that a thick voice is caused by an abundance of air, and a weak voice from the lack of it. However, one has to understand that it has to be a natural voice, not by accident or feigned, because one who will do such to appear spirited, their spirit will truly be feigned, because the works of nature can be feigned, but not altered or contradicted. Such a feigned voice will be easy to know, and much better in the summer, due to being the time in which the air is the thinnest, and thus the voice is thinner; in the winter it is thicker, and thus the voice thickens.

The chest high, understanding how important it is, as the heart (as is vulgarly said) is that which commands the body. It is certain that it does, because nothing corporeal is moved by the potency of the soul except by the vital spirit, and this has its assent in the heart. While it will be hotter, one will be found livelier, quicker, and more agile for whichever thing that will be offered to him, because of the heart being the beginning and end of natural heat, it has necessity of great refreshment, in order to conserve and be able to live, because life consists in it; this cannot be unless it will be in a wide house. Because Galen says that it is so hot from its own nature, that if the animal is alive, and we placed a finger inside its cavities, it would be impossible to be able to suffer a point without being seared. Because of this, it suits that its dwelling is somewhat spacious in proportion, so that it does not suffocate, end, and perish.

The chest

Nothing corporeal is moved by the potency of the soul.

Galen

The back has to be wide, which is commonly called stocky, so that it is equal to the chest. Thus the heart can be refreshed in suitable proportion, because if it was too wide, or extremely tall, the heat would not be enough to give it to such an aimless home, which would be like a small or large oven that with the heat, the one would be searing, and the other would be lukewarm. Such will not make use of the speed or the other parts that we require.

The back.

The arms.

The arms round and well-proportioned in length is best, because it proceeds from the heat of the heart, by being very appropriate work for its lengthening and extending, and at the same time giving spirit. I say well-proportioned because if they were long, the body being medium, it would be extreme or a vice of nature, and the strength wouldn't be much. If they were short, the body being tall, it also wouldn't be good, because it would cease extending and lack what is necessary. Being moderately rounded, it is good, and it will demonstrate having strength that it is what is required for the exercise of arms. If they were very fat, they would be fleshy, floppy, and little muscled. If they were very thin, they would not have substance or virtue; because of this, it suits that they are proportionate in all.

The fingers.

The fingers should be long, strong, and not very meaty; not so strong that being so, as well as having the strength, is the cause of much heat, as we said of the arms, and few times the long hand has been seen on the short arm, or the short hand being on the long arm. Thus one who will have long hands and fingers, proportionately, proceeding as it does from heat, from which also results in the spirit being spirited and having strength, with which fear is diminished, as Ovid said. If the hands were meaty and rough, one would have crude understanding, as it will be said when we deal with the feet. If the fingers were short and meaty, they would plainly have little strength, and this has been seen many times in those that will break horseshoes. Others prove similar, having long and strong fingers, and sinewy, or at least with little meat over them.

Fear is  
diminished  
with strength.

A lean abdomen argues for frugality and lengthening of life, because being fat can be bad if there is much exercise. That being lean suits a man for war, it satisfies us in knowing that the Greek captain Epaminondas dismissed a soldier from his camp only for being fat; with such impediment, one would neither be able to attack the enemy quickly, nor reach him if he fled, because with such a heavy load, the will cannot achieve what it desires with the speed that suits it. Having to bring the body in this exercise with such velocity to one place and another, it is plain that it suits a man to be thin and not bring with him weight that is such a burden. The abdomen.

The thighs thick and sinewy are of much strength, by being muscular, in which ordinarily there is lightness, because with the muscles one moves more lightly, as is seen each day in those that run much, who never have meaty thighs, but thick and sinewy. That lightness suits a man of war, for the skirmishes of attacking and retreating; being known, I leave it to your consideration. The thighs.

The legs in good proportion - this term of proportion, which is appreciated, has such rigor with it, that in order to make use of whichever thing perfectly, one has to lack all vice, and neither have a bad thing, nor lack a good thing. In order for the leg to be so, it has to be taken well, with the shape of its calf, and the ankle tight; this is what can be called good proportion. One who will have it thus will be agile, quick in their movements, and in whichever extreme that it will participate, too much thickness will be heavy and clumsy, and their movements will be slow, and if it will be very thin, it will not have strength or vigor in them. The legs.

That said, being in good proportion is what is required. Those that are bow-legged make use of this in particular, which generally is having them well-taken, who are commonly said to be good on horseback, and being so, it is not disliked for our exercise, rather it will be taken advantage of in the one and the other.

The feet.

The feet being lean proceeds, according to the verified opinion of those that deal with this, from the body being muscular and of temperate heat and dryness, which together with exercise does not allow creating much flesh in the feet or hands, in which there is not an abundance of blood. If they were fleshy and very thick, it would proceed from thick humors, from which thick spirits will also be engendered. The understanding of such will be crude, besides by its clumsiness and load, they would not be able to serve the understanding and will, as it suits, not achieving one's intent with the speed that such accelerated and sudden things of war require.

Plato and  
Aristotle.  
The stature of  
man has to be  
medium.

The stature, I resolutely dare to say, has to be medium, because I follow the opinion of Plato and Aristotle in this, who say that the best stature is the medium, which is not large with excess, nor small with extreme. If one had to participate in one of these extremes, it would be less harmful to be inclined to the small, because according to the opinion of those said, much bone and flesh harm the ingenuity. Besides that, custom affirms that rarely is there science in large bodies. Conforming to the opinion of philosophers, the small man is more prudent than one very tall. Without any doubt, men of good stature bring many advantages over the rest that will participate in some extreme.

Rarely is there  
science in  
large bodies.

Thus Titus Livius says that the Romans were not very tall, but that they were medium, vigorous, prudent, and wise in arms.

In the gait being composed, this being better can be known, considering in some men how little vigor they have, that it seems that each quarter falls by its part: the feet dragging, the body hunched over because of their little vigor, the steps spacious, and with strange disgrace, which are all signs of a clumsy, lazy, phlegmatic man of little spirit. On the other hand, others move the feet with a grace and composure, that one affects: the body and face upright, without some extreme with it, the step a little accelerated, with moderation, which are all signs of a choleric and spirited man. Finally, so that there is no more than saying, nor more than wanting, it is all proportionate, without participating in any extreme that makes him ugly. Since in order for a man to be said to be perfect in nature, it is necessary, according to Tullius in book 1 of *De Officiis*,<sup>33</sup> and Saint Thomas in part 1 question 39 article 8,<sup>34</sup> that one is composed of all his parts and members whole and perfect and well disposed, without there being any extreme inequality. It also suits (in particular those that had to follow the militia) that they are hungry to gain honor and wealth, because with this hunger they will undertake whichever enterprise, however arduous it may be. These were the soldiers that Cato the Younger wanted, as Plutarch refers to in the life of Marcus Marius.

If they were of temperate province, it would be better because one such would be spirited and prudent, because of that such province will participate in heat and make use of spirit.

The gait has to be composed.

Note

Men for war have to be of temperate province.

---

<sup>33</sup> *De Officiis*, Marcus Tullius Cicero, 44 BCE

<sup>34</sup> *Summa Theologiae*, Thomas Aquinas, 1485

Aristotle  
Hot lands  
produce hot  
things, and  
cold lands  
cold, and  
temperate  
lands cold and  
hot.

Because it will have dryness, it will be prudent, according to the opinion of Aristotle, who says that prudence consists of coldness, and spirit and valor of heat. He also says that hot lands produce hot things, and cold lands produce cold, and temperate lands produce cold and hot things. This is confirmed by what doctor Aben Ruiz says, that by accident, hot things originate in cold places, and cold things in hot places. When in particular the discerning master will want more and the prudent captain to know them, it will be with this consideration: a man from a cold province, being dark and hairy, will be valiant because it can be understood that he will be choleric. One that was ruddy from hot land, having a wide and tall forehead, in the manner of a lion's forehead, will also be so. Because Aristotle places many other signs in the book called Physiognomonics, the curious will see and consider them there more copiously. All of which is not so necessary that it doesn't sometimes lack, but for the most part it happens in general, as the signs indicate. Although this on the provinces is more in order to know it by curiosity, than in order to intend to join many such men. This is enough to understand that while one is more proportionate, more composed, more serious, and has a better face, it will be better to deal with this *destreza*. Over all, the best sign to know them, according to Galen, is one being virtuous and of good customs, because as Plato affirms, being bad and vicious originates from one having some intemperate quality that incites them to do bad. On the other hand, good composure and temperance inclines one to do good, which is what is also required. After this science is known, as will be said in the particular advice that we will give on the reason that the *diestro* has to have in order to fight.

## THE INTERIOR ELEMENTS

that the *diestro* has to have for more perfection.

**B**Y those signs and signals that we have referred to, nature has wanted to manifest and declare, through very conjectural suspicions, the properties of men and their secret inclinations, which God and nature placed in them. Not lacking consideration, because being a certain thing (as it is) that no one but God can know the intentions of men and their interior inclinations not being placed in action nor exercise, so that one had some relief having conjectural knowledge of that which is never dealt with nor seen. For the ministry of war, as well as for other offices, I want to place these notes and signs, by which their complexion, quality, and particular inclination can be known, more or less, by the composure of the limbs. Although not for what was said, we will close the door to one that will be among a thousand, that is missing some part of those said in the exterior, and the interiors are made better, because many times nature passes from one extreme to another, without remaining in any of the means.

Signs in  
Socrates  
different from  
the works.

Note

Placing different signs of the particular inclinations, as that worthy philosopher Socrates believed that if they had to judge one by the signs, it wouldn't have a good thing, and if they would have to see the works, they will not find a bad thing. This proposition is known, that in looking at someone, by the physiognomy of the face, one would know without error the condition of whomever, affirmed that one would have indications of a course, foolish, wanton, and drunken man, because such were the signs that were in him. The friends of Socrates being angered, they will mistreat him because of what he had said, whom they so loved, if the philosopher didn't detain them, saying: Stop, friends, so that I let you know that it has said truth in all this, because I had to be such as it says, but it gave me a will to philosophy, which has made me as you see me and changed me from what I had been into what I am; by means of it, I have broken with the inclinations that nature placed in me. In this, I came to understand well the power of free will, the lordship and greatness that it has to reign over bad inclinations. But, as we have said, this was an extreme of nature that rarely will be seen, because it is a very particular work, and the former is general. As we have said, the signs that one has to have in the exterior, by which we will come to know him and choose or reprove him for this ministry and exercise of arms, we come to the interior, which are of no less importance - rather of much more. Since each one of them has its own particular office in the republic of the soul, by which it is governed, some serving to advise on the present, others on the prevention of what comes, and others on the retaining of all.

These are of such importance that one who lacks any of them will not be perfect in the science, because however much the soul is more excellent than the body, the interior elements are that much more excellent than the exterior. Understand that in lacking some of these, the interior elements will supplement their lack, but if some of these will be missing, all the exterior elements together will not be able to remedy the smallest lack, as will be proven with this example. In the composure of the limbs, one has the referred parts without lacking some, and has reached in the interior elements clear understanding, acute ingenuity, and great prudence, but lacks memory, which is the bosom where the treasure of the sciences is kept, to take from there and distribute according to the necessity that will be offered. All will be lost, because as the office of understanding is to see and determine the things that memory will represent to it, and prudence disposes them with diligent consideration, and exercise facilitates that which the three will command, without making any more than what it has in its charge. Lacking memory to represent, understanding will stop determining, prudence will stop disposing, and exercise will not have to be occupied in that, as none will have to do it. On the other hand, making use of all the interior elements, but lacking one, such as having short arms or a narrow chest, the interior elements will supplement the lack, as it is not notable. So that you understand these elements, know that they are understanding, ingenuity, memory, prudence, and spirit.

The office of understanding, prudence, and memory.

## UNDERSTANDING and its office.

**T**HE first and most principal element is understanding, that as principal potency of the soul, has placed in its charge and has the office of contemplating all in the truth, as in its principal object. According to what Saint Augustine testified, the soul has three potencies: understanding, memory, and will. On understanding, he says that its office is comprehending and embracing all that which it has contemplated. On memory, he says that its office is conserving, guarding, or retaining the types of the things. On will, its office is desiring and loving what understanding proposed to it. As it is the office of understanding to contemplate the truth of things, it serves us as a counselor in those that we deal with. It especially teaches us how we have to be in all things, and it is the same in this exercise of arms that we deal with, to not err in what has to be done as well as what has to be avoided. The counsel that understanding gives is of such majesty that it deserves that clarified name that various Greeks gave it in saying that it is a sacred thing, because counsel not only determines the end of things, but also the means by which the end comes. Thus Sallust<sup>35</sup> advises us that we first take counsel, and being taken, we effect it with diligence, because the things that bring gravity and danger with them are not determined easily by an unwise man.

Counsel is a  
sacred thing.

This is the opinion of Titus Livius, that in the beginning of all things, it is necessary to take counsel and have audacity in working it. As the counsel that is required in the cases that are suddenly offered in the arms, one should not ask an absent friend for the present danger, and understanding is what has to give it. It suits, as we have said, that it has it good; aside from that, various counsel is necessary for various events. Only understanding will be able to give them, with a quickness that only it can comprehend, because its speed is such that no other sense can reach it, as the philosopher Thales<sup>36</sup> says in being asked what thing was the swiftest. He responded that understanding, because of its nature, is so swift, quick, and acute that it took neither work to flow by the earth, nor incurred danger in passing the sea. This is seen amazingly, because in understanding uncovering some difficulty or danger, it comes near to things that one intends to know or inquire, to the point that it facilitates and smooths it, and for a thousand dangers that are offered, it gives a thousand counsels with which to free us from them. Since no more true counsel can be given than what one will takes for themselves, and that which understanding gives, we can say in a certain form that it takes it for itself. We take it as a true friend, and one that most desires our conservation; since it has to be the counselor, in whose charge this has to be, if one had it good, it will give him good counsel, and if bad, likewise, and both are seen each day by experience. Although that said, it seems you will say to me that I clearly contradict myself in requiring understanding that is capable of giving counsel, as at the beginning I say that those that have to learn this science have to be young, and in them rarely does one find respect, as counsel is the child of long age and prudence.

Understanding is quicker than any other sense.

An objection can be placed.

Note

---

36 Thales of Miletus

Note

To this, I respond that although they are young, they have to seek to have the understanding of the old, and avoid the old who have the understanding of the young; many youths will be found virtuous, well-inclined, discerning, and good-natured, who have old thoughts in temperate age, looking at the end of the things, in which the beginning is placed with much consideration and prudence. The effects that make understanding active, possible, speculative, and practical is more for philosophers than for *diestros*; my intent is to deal with this material in ordinary and plain language. One who will be inclined to know it can see the book of Commander Geronimo de Carranza, where he will see this proposition and many others which could be desired.

## INGENUITY and its great importance.

**I**T doesn't seem to me that it will leave from our purpose, having said that understanding, the principal potency of the soul, deals with ingenuity, and how important it is to one who would want to be a *diestro*. As it is an element almost no less important than the first, and that in a certain manner it has a kinship with understanding, most of the time they go together. Those of the Italian nation pride themselves on this, and the rest are esteemed by having great liveliness of ingenuity. The ancient historians aggrandize and illustrate king Pyrrhus of Epirus, who had great and very acute ingenuity.

The Italian nation prides itself on much ingenuity. King Pyrrhus of Epirus had great ingenuity.

Proof of it is having been the first that was taught to form camp. Quintilian and other authors also say that Julius Caesar had admirable ingenuity, and in our times, our unconquered lord Carlos V, emperor of Rome and king of the Spains, since Felipe II, our lord and most worthy king of the Spains and the greater part of the world, says it all, as it is well-known that his ingenuity is more than human. If he will not fall in the vice of praising that of his which is praised, he said of his grandson Felipe III, our prince and lord, whose ingenuity surpasses his tender age with a thousand advantages, having in him all the parts that many princes have enjoyed, making him deserving of a thousand kingdoms, he will have them as powerful as theirs. Many others, whom the histories are full of, that aside from being learned, of great understanding, admirable prudence, and eternal memory, they had excellent ingenuity in the military art, where such were outdone, and such famous victories were achieved, without which it would be impossible. In men, this is easy to know because, as Seneca says, since youth gives signs and signals, and although sometimes it is inclined to the bad, and chooses the worst first, it has to be corrected with the bridle of reason and the reins of prudence, having placed will in some virtue, because there it works with more caution, and in that which ingenuity is occupied in what it knows. Thus, according to some learned ones that deal with this, it is necessary that one is inclined to the science or art that they will want to profess, and in all they have known reason, because there is no science or art that one is placed to study, that in lacking ingenuity, they leave with it, although they work in its precepts, all their life and all the diligence that they would place will be lost.

Carlos V, his son Felipe II, and his grandson Felipe III, had and have great ingenuity.

Since youth gives sign of ingenuity. Seneca. It is necessary that ingenuity is inclined to what is learned.

Why does the *diestro* have to have a good imagination?

The universal has no need of imagination, because it is the work of understanding.

Ingenuity has to have three parts.

Law of Lycurgus that it suits the *diestro* to follow.

Another author of our time says that one who will have to profess this military art needs a good imagination in order to make a squadron, form a camp, take *mangas*,<sup>37</sup> make skirmishes and other things convenient to this purpose; one has to make use of good imagination to work it, according to how the time, site, or number of enemies will dispose it. It is the same for the *destreza* that we deal with, which is one-on-one combat (in the particulars), since in the universal, imagination is not necessary because it is the office of understanding, by consisting of such certain fundamentals, like arithmetic, mathematics, and geometry (as we will deal with ahead). But in the particulars, as we have said, imagination is necessary to form one technique or another that is more suitable and more contrary to the complexion that the opponent participates in; thus the better imagination one will have, the better techniques they will form. Returning to ingenuity, know that it has to have three parts. The first is the facility to comprehend the precepts of this science, because not having this disposition, it will be as Seneca says, that what the listener doesn't reach with his ingenuity is said in vain. The second has to be copious in fabricating many techniques, not being content with only one, nor doing it many times, because of the danger that can result, which is what I wanted to remedy. Lycurgus, lawgiver of Sparta, commanded that the captains inviolably kept to the law that none of them fought with their enemy many

---

37 (lit. "sleeves") A small squad of soldiers armed with arquebuses used to support pike squares.

times; the reason was so that they didn't learn the techniques and tricks of war with which they conquered, and with them they would be conquered. The *diestro* will have this same danger, as in doing the same technique many times, the opponent will see it and learn, and when he doesn't offend him with it, at least he will seek some remedy, so that if the *diestro* will want to return to do it, it will have no effect. But doing many diverse techniques, the opponent will be intimidated by the variety of them, seeing that he does not take advantage of the remedy that he would have used to prevent the blow that he saw done, because of another being done; then, he will never find a certain point in which to be able to apply some of his defense, which had been prevented. The third is faithful, because as the friend who is not so in their counsel, harms rather than gives advantage, thus ingenuity which does not easily invent what suits the *diestro* will easily lose life, as has been seen many times. It also suits that it is well-inclined, because the inclination that the youth take at the beginning will last even into old age. One who will be curious will see this by some signs (which we give ahead), and more particularly in the words that he will speak, because the customs and the secrets of the soul are uncovered. One can see that this is certain in what happened to Socrates with the son of a gentleman that was brought into his presence by command of his father, so that the ingenuity that he had could be seen. This discerning man told the young man: speak, youth, so that he sees you. This is understood that the ingenuity of a man is not only in the face being known, but also in speech and reason.

The ingenuity of the *diestro* has to be able to invent easily.

Ingenuity is uncovered by words.

The works of ingenuity are more agreeable than those of strength.

This being important to one who would have to be a *diestro* is understood, because however much the works of the soul are greater than the body, those that we make with ingenuity come to be more agreeable than those we make with strength. Not all enjoy good ingenuity, because as Saint Augustine says, being born with good ingenuity is a particular gift from God; Socrates used to say that the youth that are well conditioned and of good ingenuity can be called children of God, because understanding is divine, and by participation, those who have this advantage can be called divine. The conclusion of this point is that it is important, in order to be a *diestro*, to have good ingenuity, as well as the sense of sight, in order to determine things.

## MEMORY and its importance.

Memory is the ark where the sciences are kept.

**H**AVING spoken on ingenuity, a very important element for the *diestro*, know that memory, which we deal with now, is no less important for being a *diestro*, by being the ark and deposit where the treasure of the sciences is kept; they are learned according to the definition of Saint Augustine, which has already been referred to. It is said that memory has the office of conserving what the understanding works, because not doing this, it is impossible to be able to work, nor to come out perfect. In the same way, if one earned much money and didn't keep it, they would never be rich.

Thus a *diestro*, however much that he studies and however many techniques they teach him, in not having memory to keep and in its time represent them, the work that was placed will be without advantage, as Quintilian affirms that we learn and are taught in vain if we forget what we learned. He also says that the first sign of good judgment in youth is having memory. As we have said, it is good that one learns when young, which is the time in which memory is most disposed, according to the doctrine of Avicenna,<sup>38</sup> which says that the reason why the youth have great memory and remember what they saw or knew is due to having the spirit reposed and unburdened by caution. Saint Thomas gives a reason (ultimately like his) that as most of the things that children and youth see are new, they appear grand to them, due to the little experience that they have, which is the reason they easily stay in their memory. On this point, Aristotle makes a problem - what is the reason that one being old has much understanding, when a young person learns more, and more easily? The response is that the memory of the old is full of the figures seen and heard over the long discourse of their life, thus wanting to give it more, it can't receive it because there is no free space for it to remain; but the memory of the young, as there has been little since they were born, retains whatever they are told and taught. Understanding does not consist of remembering of the words that the masters ordinarily use, which they call discourse, but understanding as far as one can come to the end of theory and practice; this is with the difference that Aristotle gives between the philosopher and the orator, although both studied philosophy, because the philosopher places all his study in knowing the reason and cause of whichever effect, and the orator places it in knowing the effect and no more.

One learns in vain if they forget what is learned.

Why children have great memory.

Saint Thomas

Aristotle.  
Problems

The difference between the philosopher and the orator.

---

38 Ibn Sina, Persian polymath.

In this way, the *diestro* has to seek the same, preventing the variety of blows and the circumstances of them, and of the time, as well as the person, place, mode, material, and cause, all of which is done many times to alter the execution of the blow. If the *diestro* cannot take a formed technique from their memory, or remove or place more or less parts of their movement, or slow or impede the opponent's, in whichever state that one will be found with their opponent, they will fall to a thousand errors if they will only want to follow the discourse. It also suits one to know many techniques (as we have already said); before one brings to hand what would be necessary to do expressly for the case in which one will be, memory should represent its stock to understanding, so that it can choose what suits best, according to the opponent's disposition, so that the understanding disposes a universal proposition to the will, which follows what it needs for its conservation. For this, it is necessary to have great memory, which keeps such a great number of techniques, as the particulars enclose in themselves what we deal with now. I also tell you that it is advantageous for the universal, not because they are the cause of it, but because the *diestro* will be more agile and disposed with exercise. Aside from this, Quintilian says that memory grows with its use and exercise. Many men were endowed with this and very honored and esteemed because of it, as was Mithridates the Great<sup>39</sup> who, having an army of almost innumerable men, remembered all of their names - no less amazing than having learned twenty-two languages, speaking each one as well as his mother tongue.

The universal  
is not because  
of the  
particular.  
Memory grows  
with exercise.

---

39 Mithridates VI of Pontus

Appius Claudius, who intended the Roman Censorship, gave as meritorious elements in order to deserve it, to be able to greet all the Romans, each one by their name. The famous Cineas, ambassador of King Pyrrhus, in going to Rome to deal with peace between him and the Romans, had such memory that in one day he knew almost all the Roman citizens and their names, and spoke particularly to each one. The famous Themistocles, who desired an art of being able to forget, knew so much in memory and retained so much in it, that in the span of one year, he learned the Persian language and spoke it with as much perfection as his own. As in our times, no more needs to be said than that of our king and lord Felipe II, whose memory is admired and astonishes. Finally, appreciation of millions could be brought in this being said: such a powerful prince having lordship of such kingdoms and provinces, with such variety of people coming to his royal court, one had been given leave to enter his royal presence for certain business; after five years passed, going on his way, he returned to see this man, and knew and named him. It is something worthy of admiration - this man not being someone of note, nor that he had spoken to many times, but only once, and so briefly, knowing him after just that time. Memory was always so esteemed that Cicero said that it is an argument for the immortality of the soul and divinity of man. Others called it the treasure of the sciences and mother of wisdom. Finally, memory is a natural potency, conservator of the past types; for example, I remember today what I saw yesterday. If you would want to know more excellencies of memory, read Cicero in his *Tusculans*,<sup>40</sup> Quintilian in book 11 of his *Instituciones*,<sup>41</sup> and the authors that Johannes Camers cites in chapter 7 of *Solinus*.<sup>42</sup>

Appius Claudius had a great memory. Cineas, ambassador of Pyrrhus, had a great memory.

Themistocles desired an art of forgetting.

King Felipe II had a great memory.

What Cicero said about memory.

Authors that deal with memory.

40 *Tusculanae Disputationes*, Marcus Tullius Cicero, 45 BCE

41 *Institutio Oratoria*, Marcus Fabius Quintilianus, 95 CE

42 *In C. Iulii Solini Polyistora Enarrationes*, Johannes Camers, 1520

# PRUDENCE

and its parts, which serves the *diestro*.

**T**HE importance to the *diestro* of memory, which has been dealt with, is well-known, but know that its charge is no more than keeping what is learned and representing at its time (as is said). But the disposition of things in such mode and time that they are advantageous is incumbent upon prudence, which, as faithful governor, distributes with much consideration the stock that is deposited. Many philosophers speak of its nobility and quality; so honorable are the attributes that they give it that it deserves for us to desire it with all the strength of our understanding. In particular, Aristotle, in the book on ethics, defines prudence with this appreciation: prudence is a true habit with direction of the practicable things which are good and bad for man. In other parts he says that it is a virtue of the spirit, which lets us know the bad and the good, making a representation of all for understanding. For greater appreciation, they conclude, saying that the virtue of prudence is so excellent that one who would lack it cannot have perfection, because it represses the disordered impulses, quiets the spirit, gives counsel to understanding in arduous and difficult situations, corrects the will in many things that it disorderly desires, disposes us to work the good and avoid the contrary.

Attributes of  
prudence  
Aristotle,  
Ethics.

It is (according to Tullius in the first De Officiis) a just act, according to the disposition of the place, time, and persons; it is the direct reason of our operations, and judges them to be just or unjust, licit or illicit, according to how it sees the necessity of the times. With it, one sees the present things and considers the past, and comparing the one to the other, comes to understand those that are to come. Thus, one easily knows the course of life and foresees the necessary things. It is the key of the five senses and is a particular virtue over the other virtues. This was well said by the philosopher Bion,<sup>43</sup> that the virtue of prudence has as much excellence over the other virtues as the sense of sight has over the other senses. This has three parts, each and every one very important to the *diestro*: memory of past things, to judge the present and future by them, intelligence to discern the true from the false, admonishing the harm that it has seen happen to others, and finally ordering all things well and governing them with reason. It takes much discernment for one to foresee that which is coming with the experience of the past, because things that do not appear good at their beginning sometimes go well, but not all have good outcomes. Thus it suits the *diestro* to always be advised with prudence in whatever thing that they would have to do, because otherwise it would be as Titus Livius says, that the adverse end of things is the master of the ignorant, and that which makes the foolish prudent. It is better to prevent the inconveniences and deceptions that the opponent can make once than many times, because the prudent *diestro*, in whichever occasion that is offered, first has to prevent not only that which most ordinarily happens, but that which can happen, having it all present, considering that what is not waited for comes more often.

Tullius, 1 De  
Officiis

---

43 Bion of Boristhenes

All that must be thought about how often it usually happens, so that when it will come, it is prevented and nothing, however new it is, perturbs or alters him, because the remedy and counsel that one will take at the end will be fruitless, as according to some Greek authors, events are better counsel than people. We have much experience with what happens each day, we admonish them, since it is certain that the fall of the first warns those that come after, the *diestro* has no excuse for the slightest mistake that he makes, as however small it is, disgrace and loss of life can happen. We have time as a good master which, as the philosopher Thales says, is that which knows most, as it alone finds new things and renews the past. One who will deal with *destreza* learns from it, because to their dismay, one doesn't make the adversity of the ends obey the force of reason, because a *diestro* is not permitted to say: I didn't think. Finally, understand that even though the *diestro* has said elements, and more that we will say, they will be of little importance and little advantage if he would not be prudent.

## PARTICULAR POINT ON SPIRIT and its importance.

**O**F these four elements that we have dealt with, which are those that always attend the republic of the soul, two are its principal potencies (which are understanding and memory), and ingenuity and prudence are its agents, as the effect of the one inventing and the other determining is by means of the principal cause, which is the soul.

We speak now of the spirit, which is one of the principal elements that the *diestro* has to have, because just as the spirit gives life to the body, it also gives it to the determinations that one makes in their will. Just as the bridle is not only placed on the horse to repress and detain its furious movements, but spurs are also used, in this way, though the *diestro* has the bridle of prudence to restrain the accelerated determinations in the cases that suit it, it is also important to have the spurs of spirit for the occasions that, after offered, one will not be able to avoid. Having presupposed that one who will profess this science has to be noble, it is known that they have to lack four things, which *don* Antonio de Guevara says knights and nobles lack, which are vileness, malice, falsehood, and cowardice, which can never be where there is nobility. As the gentleman knows that one has to lose their life for honor, and that one doesn't die except when honor is lost; as it is lost nowhere more shamefully than fleeing, one would lose a thousand lives before turning back one foot. Those of Numantia, which today is Soria, were so spirited in war that they were never seen having turned their backs, and would rather die than think of fleeing. The Persians had this same virtue, and the famous Antheus had a very great spirit, and the Carthaginian Hannibal's spirit was invincible. In all these, it came to happen that our Spanish people, as testified by the celebrated victories that they have won and win each day with valorous effort, which has been caused by the greatest spirit, which the children of our Spain learn about.

Considering that the spirit defeats all things, one can understand how necessary it is to the *diestro*, because one who is not improved by difficulty and danger is not strong or spirited. Low and ignorant men fear even where there is no danger; on the contrary, the noble in great danger is more enlivened there. Not having this, one would allow whatever would happen to them, due to lack of spirit, which cannot happen to those who have it. The Spartan captain Leonidas showed this well, being on campaign with his army; one of them came to him quickly, very upset, telling him: "Leonidas, the enemies are close to us." He responded to this very courageously: "Don't be disturbed, as we are also close to them," meaning that the danger was equal for both parties. The *diestro* has to have this consideration, that if the opponent will come close to them, they are enlivened and understand that they are also close to the opponent. The virtue of spirit is nothing other than a furor that commands and governs the weapons; that furor is an ignition of the spirits that vivify the virtue of fortitude. The one who fears more in battle is in more danger, and the bold and spirited is safer. As Quintilian says, one who cowardly fears puts nothing honorable into effect. Lucius Seneca said that one who is spirited and strong is of such excellence that a city surrounded by impregnable walls could be taken more easily than a valiant heart.

Alexander the Great, son of the great Phillip of Macedonia, felt this well, hearing it said that there was a rock in India so tall and unassailable that not even birds could fly to its peak, but it had a coward in its charge. He responded: Then I tell you now that it is very easy to take. Thus, although the *diestro* is at the peak of *destreza*, if they lack spirit, they will flee into the hands of death. Seneca wanted to esteem one so spirited and valiant, and said that fortune fears them, which is lord of the coward, whom fear makes a vassal, and that misfortune doesn't come to one with spirit, because it is ordinary for those who have little to flee death and follow who flees them. Because it is opportune, I will relate that which some of those who deal with *destreza* have said. Seeing this new invention exercised, as they have seen their bodies (in suitable cases) come foot to foot, what scares them most is seeing them so close, as they don't know that many times daring to die gives life. They have not heard that sentence of Seneca, that there is no danger that can be defeated without another. It seems to them that it has to be all throwing *tajos* and *reveses* from afar, seeking to prevent their opponents from coming to them. Others have taken to carrying very long swords as a remedy for this; the reason is in saying that it is best to be far from their opponent. They have seen some that profess this *destreza*, although with a shorter sword than usual, come to their opponent such that the arrogant and long sword has no way to impede it, rather, the short sword impedes it easily with its bold and superb movements. They condemn it as bad, because their spirits don't dare, nor their understanding reach to know how it has to be worked.

Objection of some *diestros*.

Why do some carry long swords?

With this, they come to believe that long swords are good and condemn the short, believing otherwise in men that, naturally, without being guided by some art or science, with great valor and spirit, fought with their enemies with such short swords that those who know less usually always made fun of them. This happened to the Spartan Agis, to whom came a man from a different nation, asking him why the swords of the Spartans were so small that because of their shortness, jugglers would be able to swallow them whole. He responded valiantly to this, saying: know that the Spartans with such short swords reach their enemies that carry very long swords, because we reach them with spirit. It is the response of a valorous man, as it suggested that it suits one who would carry a short sword to lengthen the step toward their opponent. That which Antalcidas (also a Spartan) said was no less, in being asked the same question. He responded that they overcome although they are so short, because we fight with our enemies hand to hand. But we don't give all the praise to strangers, as our mother Spain is not sterile in producing spirited and vigorous children. A gentleman friend of mine from Toledo carried a sword as short as any said, who was asked why he carried one so short. The response was not only spirited, but discerning, saying: I carry it so short because when I defeat my enemy, it is a more esteemed victory, and because that which it lacks in length, I have to make up for in spirit, and the main thing is because my opponent fears me, seeing me close to them.

But that there are some who fear those who have spirit, as the son of a Spartan woman, saying to her that the sword that he had was very short. She responded valiantly: for that, Son, lengthen your step and you will reach your enemy, and thus you won't lack anything. Because our Spaniards, well-known and without any doubt, bring a thousand advantages in spirit over all the other nations, as there are none whom they don't have oppressed and subjected, have to annihilate their spirits and subject them to a vain imagination of having more faith in four fingers of sword than their spirit. But we leave this and conclude, saying that just as the body doesn't live more than as much as the soul is in it, whichever part of *destreza* will also not have more life than what the spirit will give.

## THE ELEMENTS THAT THE MASTER will have to have to teach this *destreza*.

**A**T the beginning of this book, we suggested that in order to learn this *destreza*, it is not necessary for a master to teach it, with respect to its demonstrations, which are manifested with lines and numbers. They show the convenient place in which the *diestro* has to be positioned to give the blow,<sup>44</sup> form the parry,<sup>45</sup> or impede or delay the opponent's movement when he will want, whatever species that it is (not because heaven wanted to enrich your understanding with such elements, which will rarely be seen in so tender an age). Understand that all will be equal to you, because the distributor of these gifts distributes and divides them as he will, giving more or less to each one as he pleases.

---

44 *herida*

45 *reparo*

We own much  
to those that  
warn us on  
what we err.

Because there will be some that do not want to suffer work in inquiring the order that has to be had (although it is clear and easy), following in this the style of the princes that have *maestresalas*;<sup>46</sup> whichever bird that they have to eat, they prepare and cut it, and thus disposed, place it on the table, not because the prince wouldn't know how to do it as well and better, but for greatness, as it certainly is. They want to have masters that give them *destreza* disposed and facilitated in ends, and also because there will be others who, reading this book and understanding almost nothing of it, want to rise up with the lordship of everything essential that will be beyond their understanding. We will place a general prevention here so that the youths (by being so) are not deceived in choosing a master, which suits for a doctrine of such importance as what we deal with. When they will find one with the elements that we will place here, they know to esteem and value them. As Plato says, we owe much to those that warn us on what we err in and advise us on what we have to do. This is confirmed by the great reverence that king Alexander had for his master, the philosopher Aristotle, who said that one owes them no less than their own father, because one had received the beginning of life from their father, and a good life from their master. Since one has to appreciate being a disciple of a good master, wise and virtuous as of noble and principal parents, as truly the one and the other are. This should be sought and chosen among many, and not whomever, but sought and examined with much care, that is of great virtue and credit.

---

46 A *maestresala* is a head table servant, who also functions as a taster.

Because Aristotle says that it is necessary that one who learns has to believe their master, and also that for one who teaches another, it suits them to tell the truth. With this diligence, that which happened to a friend of mine will not happen – having learned many techniques from a master (that certain for a disciple did not have to be admitted), being offered an occasion in which to valorously place hand to sword, he wanted to do a technique which he trusted to victory, but the opposite happened, as he was badly wounded. Asking him how that had happened, he responded I trusted my master, because with the name, he brought my credit and confidence to him, thinking that by being a master, he could not err. This is the greatest harm of being called masters, because the name impedes them from working to know what they lack so that they truly are, and are content with the name without works, though the works without name is better. This is very contrary to the desire that the philosopher Socrates had to know, as it was usually said that he taught others for ten *doblas* or *libras*,<sup>47</sup> but that if he had some that he taught what they lacked, they would give ten thousand, such was their greed of knowing.

The disciple is obligated to believe their master.

Folly of a master.

The master should be wise in the *destreza* of arms, knowing the parts that each blow has. This is not by chance, but with much certainty, because one cannot be said to know what the cause is for some disgrace or death, as has happened to many masters that have invented some harmful and very dangerous techniques. God permitted that what they invented with malice, they knew before others by the experience of losing life. It is a just punishment of heaven that whoever invents something to harm their neighbor suffers it first, because one who plots with malice and seeks the death of their neighbor finds his own by the same path.

The master has to be wise.

---

47 units of money

This happened to Perillos, who gave Phalaris the tyrant that bronze bull, invented by that demonic ingenuity only to torment men with a new type of torment. Righteous heaven permitted that by command of the king, he was the first that experienced and died in it. Here is fulfilled that which the wise said, that one who searches out bad things will be oppressed by them. The same happened to Cleisthenes, who was the first in Athens to invent ostracism, and was the first that the Athenians ostracized.

It also suits that one is wise and relaxed, of mature understanding, acute ingenuity, and enough experience, spending some time in the study of this science. It is very convenient that the master begins to work before teaching, as working well, one will teach well, and otherwise for the opposite, as it is certain that we are as obligated to imitate what they do as to learn what they say. That which happened to that youth that Plato taught makes this certain; as the time of vacations came and he went to his father's house, as one day he saw him laughing too much, he told him: Son, you have not been right, because I have never seen you do such a thing to your master.

The master has to be spirited.

Example that the eagle gives to its offspring.

It suits that one is spirited and vigorous, because it will be bad to teach one to attack when their spirit is inclined to retreat. But their disciples would amazingly stop being so if one would be spirited, as one will do with them what nature says that the eagle, queen of all birds, does when its offspring are old enough to fly and sustain themselves, because it takes them from the nest and catches any other small bird or animal, and tears it apart in front of them to teach them how they to hunt.

The masters have to do this in front of their disciples, exercising the *destreza* that they will teach them, so that in seeing it, they imitate it. If they had the nature of a rabbit, when it takes its offspring to the field, not only does it not teach them to attack nor hunt, but it teaches them the most secret paths by which they have to flee. Whichever of these things that the master does, their disciples will imitate, because human hearts are more persuaded with the works that they see than with the words that they hear, not because the master can give spirit to anyone, but with the science that they will teach, and with the example that they will give, they can make some daring who were not before. These are the elements with which a discerning person has to search for a master that gives enough satisfaction in the science that they will profess that one knows it with certainty, because one is not fulfilled by the sentence of Terence,<sup>48</sup> that says that the fortunate or unfortunate events are the true masters that make the foolish prudent. But if one will be found perfect, and the reasons that they will give will leave the understanding satisfied, then be obedient to their precepts. As Aristotle said to a doctor, coming to visit for a grave illness that he suffered, who ordered him to do certain things with his authority without giving him reason; because it was not founded in it, he told him: don't think that you have to heal me like a cowherd or miner, rather, you have to teach me the cause and reason of what you order, and thus you will find me obedient. The discerning person has to do the same when their master will give them some lesson or technique, asking the provable cause and reasons for it.

That which the rabbit does with its offspring.

Hearts are moved more with works than with words.

What happened to Aristotle with a doctor.

---

48 Publius Terentius Afer, Roman African playwright.

What the Indians do with their diviners.

The liar cannot be accepted by noble people.

Aristotle

Praiseworthy custom of the Mapuche.

The meaning of "fencing" and "fencer."

Not giving them, one does with them what the Indians do with their diviners, whom they had as philosophers and believed what they said; if some time they were not right, the penalty was already established that they were silenced forever, and that if some spoke, they were not believed. A very just sentence, because the liar cannot be accepted by noble people, who always deal with the truth. In this, it seems that they found success with that saying of Aristotle, asking him what liars gained from lying, he responded that they are not believed when they will tell the truth. Although heathens, they give themselves a notable advantage in a praiseworthy custom, and in particular in choosing masters, or permitting them in the republics, having made an ordinance that no artisan left their trade and took another, nor that a man of war became a laborer, nor an artisan a philosopher, but that each one made use of what they knew. This is very different from what is permitted today in the Spains, and especially the matter that we deal with, as whichever mechanical artisan, whose understanding doesn't reach to the least important of their trade, leaves it and takes to being a fencer, becoming a master of fencing [*esgrima*]. It is a very appropriate name for what they teach, because the name *grima* is the same (in our Castilian) as a thing that brings fear and danger, and they say very well it is *grima* [*es grima*], and they are masters of *grima*, which is the same as fear. As such, there is much distinction between a master of arms and a master of fencing, because the former is one who teaches the causes and effects that are produced by the arms scientifically with provable reasons, and this is the good that we have to esteem, and the latter is a master of fencing, which is the same as saying a master that teaches a fearful thing.

Thus, noble and discerning people should have to know and learn such a thing, like a discerning gentleman that, having called on a master of fencing to teach him, considering that in little more than the two hours that he was teaching him, the lessons began with the sword, continued with the dagger, small and large buckler, shield,<sup>49</sup> *montante*,<sup>50</sup> axe, mace, pike, and halberd – and the worst was telling him that he was already a *diestro*. Seeing the notable lack in both the master and what he taught, the prudent gentleman took the fee from his desk that would have been enough for much time of good and certain *destreza*, and gave it to him, saying: Take this, master, and note that I don't give this to you for what you have to teach me, nor for what you have taught me, but because you have uncovered to me the little certainty that there is in fencing, and the folly on which it is founded; neither do I pay you for having come to my house, but so that you will not come back. The discerning have to do this, believing it better to pay them so that they don't teach them, than after having deceived them, since we see clearly that those that are bad masters kill more with their doctrine than a great plague. It had the result from here that the republics placed great caution in examining the masters that have to teach their children and give them a particular salary so that they taught them with love, not consenting that it was done in any other manner. Then such masters would seek to know more than what they know, study more than what they study, and presume less than what they presume, and the good will be esteemed as such, and in that which it deserves.

Note that is admirable.

That which suits the republics to do with the masters of arms.

---

49 *rodela*

50 A two-handed sword up to six feet in length.

Why the emperor Honorius banished the fencers.

One who will teach the art of war has to have exercised it for a long time.

This cannot be today, by having the barbarism that there is, and wanting that one who knows least is esteemed like one who has worked more, because the *destreza* itself is good, but those that profess it either don't understand it or don't want to teach it. But it is compassion that in a republic, until the crier seeks the best, and the master of their children many times is the worst. Surely, if they were in time of the Roman emperor Honorius, he would banish them like the gladiators of that time, because those he banished were killed like beasts in the festivals that they had; many of them would deserve the same, because as they are not killed (because they are kept well), they are the reason others are killed, by trusting in their words. Each one being in their trade, each one does what they know, exercising what they learned, as it is a great ignorance (as Socrates says) to want to rule over others when one can't rule over themselves. They hear that saying of Plutarch that says that the art of war is taught by one who had used it many times, because one cannot teach another to be skilled when they themselves are not. As it is certain that it is difficult to learn from many what is in few, it is just that good republics have caution that each one makes use of their trade. In this, they will serve God and King, in seeking that the masters of arms are as we have said, so that when they will have deserved soldiers (which is necessary each day it is offered, with respect to the continuous wars and many enemies that our mother Spain has made), one finds them so skilled that confidence can be had in victory. Aside from that, in the hand of other artisans, only wealth is lost, but in that of the masters of arms, wealth and life.

Because the bad master robs wealth and affronts the person, as in the occasion so that one learns, or ends up dead or wounded, due to what they teach being false. Thus the *destreza* that is in the hands of a serious, prudent, wise, and experienced master is praiseworthy, as with the science one will know, and with prudence and wisdom one will choose what suits, and with experience one will know to apply it. But the presumption of some masters has come to such, and the consideration of the disciples so little, that all that which the former say, the latter believe without consideration; that which the masters invent by night, they believe by day, as if it were verified with infallible truth. I only fear that having such noble disciples of good understanding, there is no one on hand so they know the error they make, the danger in which they put themselves, and the disastrous end that many have had by having followed the same they follow. It amazes me that there are none of the other vulgars that fears, because the vulgar is so frivolous of theirs that they are pleased with the novelty, although it is uncertain and harmful; they truly love new inventions - the stranger the thing is that they are told, the more they love it. It is a shame that they don't know their own harm, that one believing all that they hear, and doing all that they see, it happens with little judgment and a frivolous heart. Being persuaded by whichever word and saying of whichever person shows that one is of little understanding. It is the sentence of Erasmus that one who will easily believe another cannot be prudent. I say that when the master will give some lesson, that the disciple examines and experiences it, to see if it (in the necessary occasions for which it is learned) can be trusted, and not taking it without thought (as they say) without wanting to examine the parts it has, from which principles it proceeds, and what ends can be waited for.

What a bad master does.

Such is the vulgar.

The ordinary  
*destreza* was  
not as bad as it  
is today.

It is a great frivolity to easily believe what cannot be proven by reason, and that which is founded in none. Looking to be given something that leaves understanding satisfied, and the spirit quiet; to a person of reason, reasons convince them. In this manner, and with this diligence, one has to receive whatever lesson, as believing it without them is an unjust faith, credit badly employed, undue confidence, and danger as certain as it is doubtful. It is a grave shame to see how many masters rose with *destreza*, which is a certain sign that it is lost. According to Plato, there is no greater indication of a republic being lost than when many heads rise in it, and because of this, *destreza* that has been practiced up to now has been lost. Although it was not as bad as it is today, and the republic of true *destreza* will also be lost if the noble people of good understanding do not favor it and free it from the hands of those that we have said. To those to whom it will appear that I am harsh in reprehending, forgive me, as it is certain that the vices that they have in public cannot be removed with flattery or secret words – public vices, public reprehension. What I say suits them, as the good or bad that they will do will give them advantage or harm them. I dare to say and certify that the punishment has to come as quickly as they will commit the mistake. Time has given me word to go out by my surety, making me a true and certain prognosticator. Much was offered to me to say, but my intent is not to disgust anyone, rather to persuade all, not telling them a thing that weighs on them, but warning them of things that advantage them.

THE ELEMENTS THAT THE DISCIPLE  
 who would want to be taught this *destreza* has to have  
 and the master is given the order how one has to teach  
 and at what time.

**W**E have said to the disciple what master they have to choose, and the elements with which one has to seek them, and the qualities that they have to have, with which one will not be deceived. It is just that we say to the master what disciples they have to receive, how one has to know them, and how one has to teach them. It will not be reasonable, being as we have said, that one spends their time teaching disciples, who inclinations and spirits do not equal nor conform to what they want to profess. Because just as not all people can be masters, neither can all be disciples. Aside from which, good, noble, and well-inclined disciples deserve good, wise, and experienced masters. That this is reasonable, we see in the most celebrated men that there have been in letters, who they have had as disciples. We will see that the worthy philosopher Aristotle had Alexander, and was so appreciated in being his disciple, as Aristotle was in being his master. The celebrated Seneca had as his disciple the emperor Nero, Policrato had emperor Trajan, the philosopher Chilon had Leandro, our lord and emperor of Rome Carlos V was a disciple of Adrian, who was later Pope Adrian VI, and his son and our lord Felipe II, king of the Spains, had as his master Siliceo, who was later Archbishop of Toledo - all men so wise that when some will be found such, they are not better.

Celebrated  
 masters and  
 illustrious  
 disciples.

Letter from  
Alexander to  
his master  
Aristotle.

When one would have notice and knowledge of the science of arms, and there would be men so esteemed in it, those in letters will also call them to service. Thus, disciples so serious, so powerful, and so illustrious were suited for masters so wise, so prudent, and so excellent in letters. This is the prize of those that spend their life, however long it is, working to come to the greatest perfection that their understandings can reach; princes honor them, by being served by them. Aside from which, they are important, as however greater the power they would have, the greater the masters they have to seek, because just as they give advantage to all their vassals in riches and power and the rest, they also have to bring advantage in knowing. Alexander said this well, knowing that his master Aristotle had published certain books on natural philosophy that he had heard of, in a letter that he wrote to him that contained these words: Certainly Aristotle, you have done bad in publishing the philosophy books that you wrote, and I heard of, because how do you believe that I will exceed other men if what you taught me begins to be common to all? This weighs on me, because I would have you know that in science and doctrine, I want to have advantage in all, not in riches and power. With this, the master would understand the diligence that one had placed in seeking disciples, that when they are not as excellent as those said, at least they are with the elements to which we will refer.

On the contrary, besides being tired without effect, one would not lack blame for the bad that they would do and the least defect that they had, because people always attribute the imperfections of disciples to their masters. That which happened to Diogenes with a youth shows that this is true; seeing him dishonest and ill-bred, he went to his master and struck him with the staff that he always carried, saying: Take that, because you taught him to be this way. The philosopher Plutarch wrote to Trajan, his disciple, that all the harm, mistakes, and defects of the disciples fall on the masters, which permits them little rest. There are doubtful ends in their disciples, because there are some whose ingenuity is such that study is not enough to wake them, and in such occasion, the parents lose the cost, the master loses the work, and the disciple loses the time, and over all, the reputation of the poor master is almost lost. From this, one comes to understand that the state of the disciple is more secure than their master's; just as the soldier's is more secure than the captain's; it has been seen many times that although one is a valorous warrior, and with his sword in battle opens a path in the enemy's chest with valor and vigor, if victory is lost (or not reached) due to the cowardice of their soldiers, the blame is placed on the poor captain. On the contrary, if victory is achieved even though the captain doesn't have the elements that are required for such office, except for the valor and vigor of the soldiers, the glory of the conquest is attributed to him, and it is never said that soldiers won said battle, but Captain So-and-so defeated said enemy, conquered said force, broke said army;

People attribute the imperfections of the disciples to the masters.

The state of the disciple is more secure than that of the master, and that of the soldier more than that of the captain.

it is ordinary to attribute adverse or prosperous occurrences to the leaders. Since the histories are full of this, we come to our purpose, of which I say that the good or bad that a disciple will do has to be attributed to the honor or guilt of their master; it is also ordinary for a wise man, in whatever faculty, to say he had a good master. As we have given an almost infallible rule to the captains to know the soldiers that they have to choose, and the military art and teaching the exercising of arms are the same, such that those that had sought most that the republics had masters with said elements, they had to be the captains themselves, as these teach in their homes and in peace what one has to do when they will be with the captains in war. If they will be good masters, they will teach well, in the time of necessity (which is where they are necessary) it will not weigh on them to find them skilled and spirited, since, as we have said, science increased the spirit. Thus, the master can also take this rule, in what touches the exterior elements and signs for the limbs and proportion of them; being good for one, they would be so for another, as both things depend on each other and are causes for the same effect. I will advise them also for the interior, as they will know them, and we will give some documents how they have to be with them, which will not be of little importance.

The captains had to seek with caution that there were good masters of arms.

The first diligence that the master has to do with the disciple is to know if they are noble and known in virtue, because nobility and virtue are always inclined to good.

The first thing that the master has to know in the disciple.

In general, the noble are always of generous spirit, not subject to any passion, nor given to vainglory, nor arrogant presumption. There is nothing that obligates one more in war than being of good blood, because such make use of those five particular gifts that *don Antonio de Guevara* says, which are: spirit to not flee, generosity in giving, credibility in speaking, heart for daring, and clemency for forgiving. One who will teach a proud disciple will not come out with their intent, because pride is the enemy of ingenuity and a companion of little spirit. Just as the swelling of the eyes harms vision, swelling of spirit harms ingenuity.

That which obligates one most in war.

Pride is the enemy of ingenuity.

The discerning master also sees that the disciples that will be chosen are favored by the particular gifts that we have said before, which are understanding, ingenuity, memory, prudence, and spirit. It will easily be seen if one will have understanding in comprehending quickly what they are taught, because one who will teach a dull disciple will till in dry ground and work in vain. If one will have spirit in the determination with which they work, there is no greater pleasure for one who teaches than seeing their disciples skilled in what they are taught. On the contrary, just as the painter is sorry to see their painting marred, that they painted with great artifice and in which they placed the strengths of their ingenuity. Thus the master is sorry to see their disciple marred, whom they taught with great industry and work, in which their doctrine is so badly employed. The disciple is also obligated to work on their part to come out perfect, because no one can be a *diestro* through the work of only the master.

The second thing that the master has to consider in the disciple.

There is no greater pleasure for a master than seeing their disciples skilled.

Aristotle, how the disciples will take advantage.

This is what Aristotle responded with, being asked how it could be that the disciples took advantage in much, saying: Those that remain behind work to reach those ahead, and those ahead aren't careless. With this, it is clearly seen that the disciple is obligated to work on their part, and the master will not be deceived in the choice of disciples. It only remains to know how one has to be with them, so that their work is advantageous.

The third thing that the master has to consider in the disciple in the age.

The master, having known those disposed to profess the arms by the signs that we give, has to consider their age, that they are neither young nor too old, as both are impossibilities – the former because their limbs have not reached the strength that is required, and the latter have lost it. It seems to me the youngest should be eighteen years, which is the age in which they toughen up and gain strength to be able to handle arms, but have the capacity to receive and comprehend what they will be taught. There are many of this age that, in body as well as understanding, don't have the disposition for something of such study and work. The other age is twenty-five years, which is the time when understanding is disposed and the limbs are more apt and robust for the continuous exercise that is required. This will rarely be found in those that pass this age, as such movements and actions will not be so easy or agile, and their understanding will be occupied with caution, which will be an impediment to them. Some that will pass from the age that we say and have other elements that will cover and supplement if there will be some lack.

It remains to the disposition and judgment of the discerning master, because a certain rule cannot be given on age, because some people of fifteen years are enough, and other of twenty are young, others of forty are old, and others of fifty have the disposition of thirty. Thus, Aristotle says in the first of Ethics that people are said to be old and young according to age, customs, and works, and Pliny in book 11 chapter 37 says that one of twenty-one years is already robust, and their nature has already come to perfection. With that said, we don't want to persuade you that one who will be forty or more will not be able to learn part of *destreza*, which is enough to be defended. In this occasion, the master will be able to take advantage of teaching them some blows that are called second intention, which many times are not necessary to be done with quick movements, and many times it happens that without any of its part preceding, the intent to wound the opponent is achieved. When one will not want to wound or kill (because *destreza* doesn't obligate it), one will be able to impede the opponent's movements with some *atajos* (which we will declare ahead), but will not make use of that speed that the young will, due to said causes, and because the strengths have already faded, and the heat is not such.

When are people old? Aristotle, Ethics. Pliny, book 11.

In beginning to teach them, I am of the opinion that they are exercised first, if they otherwise would not be, in running, jumping, bar throwing,<sup>51</sup> playing ball, playing an instrument and dancing.

What the master has to exercise their disciples in.

---

51 A children's game

The ball game consists of the same violent and natural movements as the arms.

Carranza, folio 148.

Idem, fol. 151.

The exercise of running makes one agile, thin, and healthy, and jumping in a certain manner, but because one has to lift the whole body and suspend it in the air for this exercise without resting on the feet, which one who runs doesn't do, which helps both. Bar throwing creates strength in the arm in order to handle the sword. Playing ball is important to know the movements, because the ball game is composed of violent and natural movement, where it is necessary to know the nature of each one. Sometimes one waits for the voyage that it makes to end, by virtue of the strength that is communicated in that distance that there is from the bounce to the place where the defenders are, which is where the natural movement begins and is generated, although many times it is resisted before the one ends or the other begins. Having knowledge of this, one will take advantage of knowing the movements in the arms, since they are composed of the same, and many times it will suit them to comport oneself with them as with the ball, some waiting for the natural movement, and others at the beginning of the violent, and some without the one ending or the other beginning. Playing an instrument and dancing is so that one knows the consonance and gives the steps in their point, that the body, arm, and blow, not each thing by itself, but all together, make a true consonance of music; here is where *destreza* is equal to it, as Geronimo de Carranza says. For this, it would be good that the disciple makes use of some shoes that have lead between the two soles, walking with them some days, until the point that one has to exercise the arms or dance; having walked with that weight, when one will remove it, they will be found so agile that the movements that they will do will be almost incomprehensible.

It has been ordinary for masters up to now, in some parts, to give lessons to their disciples at night. Although I have sought to know the origin of this custom, I have not been able to find it. It has just been an introduction already received, then it suits our master to make use of the morning. That this is better and more advantageous, I place by the author Aristotle, as he says that memory is easier in the morning than the evening, because the sleep of the past night has moistened and fortified the brain. As memory is a part of wetness, and sleep brings this, the morning is when it is more disposed to receive, rather than at night, when the vigil of all the day has dried and hardened it.

Aside from what has been said, it is necessary for the master, in order to be certain, to know which complexion the disciple participates most in, so that one is not deceived in giving to one what the spirit of another requires. To one who would be choleric, whose spirit is to attack due to the participation it has in the element of fire, it will suit to teach doctrine that is equal to this spirit, which are blows of first intention (which will be given in the discourse of this book). The sanguine, due to the participation in the element of air and heat of the blood that particularly predominates, also have their determinations and attacks,<sup>52</sup> and it will suit to teach them how they have to attack. The phlegmatic, due to participating in the element of water, which is heavy, will not be accelerated in their movements, but inclined to wound without much diligence on their part; they will have to be taught phlegmatic blows, which are of second intention.

At what time the disciples have to be given lessons.

Aristotle, that memory is more disposed in the morning than at night.

The fourth and most important thing that the master has to know in the disciple.

---

<sup>52</sup> *acometimientos*

Carranza, folio  
177.

The master  
notes and  
does.

Seneca, that  
which is  
learned in a  
long time is  
slowly  
forgotten.

To the melancholy, due to participating in earth, aside from being slothful and slow in their movements, most of the time they are fainthearted and ruled by fear, (so that they lose it) one must teach them to only defend, impeding and placing *atajo* on whichever blow that the opponent will form, whichever species it is, with which one will not see the lack that they naturally have. Geronimo de Carranza says to this effect that the disciple has to tell the truth to their master like a confessor, showing whether they have spirit or not. But one required a thing that they will never accomplish, because none will understand that they have this lack; when they do understand it, they will not say it due to their honor, because the presumption has this seriousness with itself. When they will not say it, one will be able to know them as we will advise ahead in the particular point that we make in knowing the complexions. One will be able to see the signs that each person has, so they will not be deceived in knowing their spirit and inclination, so that as one could, they come out perfect and don't lack on their part. But one must take note that the lesson that will be given is with language that conforms to the capacity in which they will learn. Not being content with saying it only once, but many times, because this will result in making clear what was obscure, dividing it into parts and declaring it with examples, because that which is divided into parts makes for easier understanding. The disciple that will comprehend it in this way will never forget it; the saying of Seneca testifies well to this, that what is well-learned over much time is slowly forgotten. Over all, one teaches them the true cause of what they will be told, as then a thing will be known well when its cause will be known.

With this, the disciples will be skilled in a short time, being able to employ well what they will spend in such noble exercise. The master will be content in seeing that the work that had been suffered in teaching them is the reason for working with certainty, as there is nowhere that the knowledge of the learned master shines more than in their disciples coming out skilled.

## JUDGMENT OF THE TWO DESTREZAS, true and false.

**I**T is a celebrated sentence of Aristotle that it is not enough to tell the truth, but that it suits to prove the cause of its opposite, so that it can be known better, because bad being close to good makes it seem better. It is well-founded in reason that in all conclusions and disputes, the first to be dealt with is to define the subject being spoken of, so that there is no error, as well as for excellence of the same, because the definition of the argument is the beginning of knowing the thing being argued. Just as two contrary things oppose each other, but are manifested and declared (because in having notice of a contrary, one comes to knowledge of the other), in order to know which the true and the false *destreza*, it is also necessary to counterpose the one with the other. With this, we will come to know what the fundamentals and reasons are, because it appears to me that it will not be enough to persuade them to leave the false *destreza* that they have dealt with up to now and exercise the true confidently, even though the opinion that the philosopher Antisthenes gives is well known;

All that which is done is in one of three manners. The defense of animals is by nature.

The defense of the common *destreza* is by chance.

he says that the most perfect doctrine that one can learn is to forget what is known if it is not certain and true, but the principal causes on which each one is founded are declared and manifest. This will result in a clear notice and certain knowledge of the certainty of the one and the falsehood of the other, and at the same time love and desire of the one, and hate and abhorrence of the other. For this persuasion, two things usually have great strength, which are reason and authority. Because reason has its foundation and root in natural light, and authority in prudence, we will have to make use of these. Plato says that all that which is done is in one of three manners: either by nature, by chance, or by art. For our purpose, we place three types of defense in these three. We say that which irrational animals have in themselves is by nature, and they are defended from their opponents by means of that natural instinct and knowledge that it gave them. Having provided arms to each one according to what suited them, when they see that their opponents want to offend them, they naturally defend themselves and make use of them. Although they have no rational knowledge in order to know when and from whom they have to be defended, they have natural and sensible knowledge for it. That which is done by chance is what sometimes has effect and others not. Sometimes it seems infallible, and more often it lacks, as when one does something (as they say) without thought or haphazardly, if it will come out well. But also, by not knowing the means by which they have to reach the end that they seek, nor the fundamentals on which they have to be founded for such work, they begin it uncertainly and confusingly, without other knowledge, being founded in vulgar opinion.

This is a dark and doubtful knowledge of the thing that is practiced, and an estimation and doubtful knowledge of those that don't have certain and clear notice, which can more justly be called vulgar error than opinion. There is a difference between this and reason, as opinion not verified or founded in certainty always goes far from the truth, and reason always follows it as its true end. It proceeds from this that all that which is founded in such opinion sometimes succeeds and other times lacks, which we can justly call arbitrary luck, because what perhaps comes to its effect cannot be called art or science, nor can one expect certainty when each one makes a law of their will and desire without following more order or reason than their own whim. The truth of this is seen each day in the masters of fencing, who are not scientific, and invent new techniques and lessons, leaving the past as something already old, as if they were shoes that are broken or a cloak that is frayed. They are very content with their new inventions, saying that they know modern techniques, which are newly used, as if the composure of one's limbs and their movements are different from the past. They don't see, and don't want to see and be certain, that the variety of times and customs don't change, and cannot change, the certainty of the sciences; rather, they measure and subject the rest equally. Aside from that, good and artful things always appear new to us, and this reason was enough that Aristotle wondered and said that when something is done or happens whose occurrence is by chance, it is shocking or miraculous.

The difference between opinion and reason.

Aristotle says the thing that happens by chance is shocking.

When said to only our purpose, it was a very well-known reason, because the techniques that are most commonly used by those who deal with the ordinary *destreza*, even in which they trust more, when they want to make use of them, they work with some people and not others, one day and not another, with various luck and not on one's own. Since the causes are uncertain, the effects that proceed from them have to be uncertain, because from uncertain cause, one cannot expect certain and infallible effect (because there is none).

The defense  
that is done by  
art.

The truth is in  
all its parts.

That which is done by art is with scientific fundamentals, from which proceed infallible effects, because if there really is truth in something once, it will have it many times, even though it is in diverse manners, because the truth is in all its parts. Take arithmetic for example: we say that three times eight is twenty-four, and we will see then that four times six will be the same, and six times four, the same, and eight times three will also be twenty-four. However many times we will balance the numbers proportionately for said sum, it will not lack; we will come to take the truth of the sum clearly, without lacking, because it is an art founded on certain principles. In this way, if a *diestro* of true *destreza* did a technique of second intention (which is by means of the opponent's movement), how we say: his opponent formed or wanted to give the most rigorous *reves* in the head that one can consider, whose proper and common place is executing it on the right side, not depriving the *diestro* of being able to guide it where they will want, as we say in another part, dealing with it in its proper place.

In order to be defended from said *reves* without parrying, with only the blow that one will give serving as a parry, it is necessary to give a curved step<sup>53</sup> on the left-hand side of the circumference and form another *reves* and offend them with it. As Carranza says, a formed technique<sup>54</sup> is when the opponent does a technique of *reves*, and another is taken from the same *reves* with which they will wound them, it would be free and found certain in the effect. But if one wanted to wound with a thrust below the sword arm, giving the same step while the violent movement is formed, one would find the same certainty and defense. If one wanted, when the natural movement had lowered, to give the same step and wound straight in the chest, without any fault they will find effect and defense. If one wanted, also when the natural movement lowered, to put in the left foot, profiling the body, to wound with a thrust in the chest above the opponent's sword, one would offend without being in danger. At the beginning of the offline lateral movement, before the violent is generated, when one wanted to wound with a thrust in the chest, they could. At the beginning of the violent movement, before the natural is generated, if one wanted to form a *tajo*, their intent would succeed. According to our author, *tajo* is formed against *reves*, and *reves* against *tajo*, and offending with it, one would remain without danger. Finally, however many times one will do, by means of said step, whichever of these blows, they will find certainty due to the inequality that there is in the steps and lines; the opposite will never happen, not could it lack. The reason those who deal with the false *destreza* lack this certainty is because they want to live by vulgar and false imitation of what they see, going behind the countenance of the people, not behind the science and fundamentals on which it is founded.

Carranza,  
declaration,  
folio 2.

---

53 *compás curvo*

54 *treta formada*

For this, Seneca says that in living according to the people, one lives basely and faintly. As they have occupied their understanding with this base opinion, they don't understand whether what they know is bad or good, and the things that they profess and know are not only bad, but the bad that comes from it is much worse, as is seen at times. Finally, with all this that we persuade them, and with the long experience they have of it, there have to be many that, being disillusioned of this vulgar opinion and falsehood, don't have to give space for the truth to disillusion them. Since we have argued to this point and concluded with reasons certain enough to conquer your will and whichever other that will not have prevaricated it. We come to the use of *destreza*, dividing this work into five parts, as we said and placed at the beginning of this book, beginning with the particular fundamentals and precepts that you have to keep to in order to work it better, placed in demonstrations.

This work is divided into five parts.

SECOND PART,  
WHICH PLACES THE FUNDAMENTALS  
of the true *destreza* in demonstration and particular  
precepts that one who will want to be a *diestro* has to  
keep to.

WITHOUT WHICH IT WILL BE IMPOSSIBLE  
to know or understand it, or even have safety of your  
person.

With a warning of particular things that serve as prevention for  
what lies ahead.



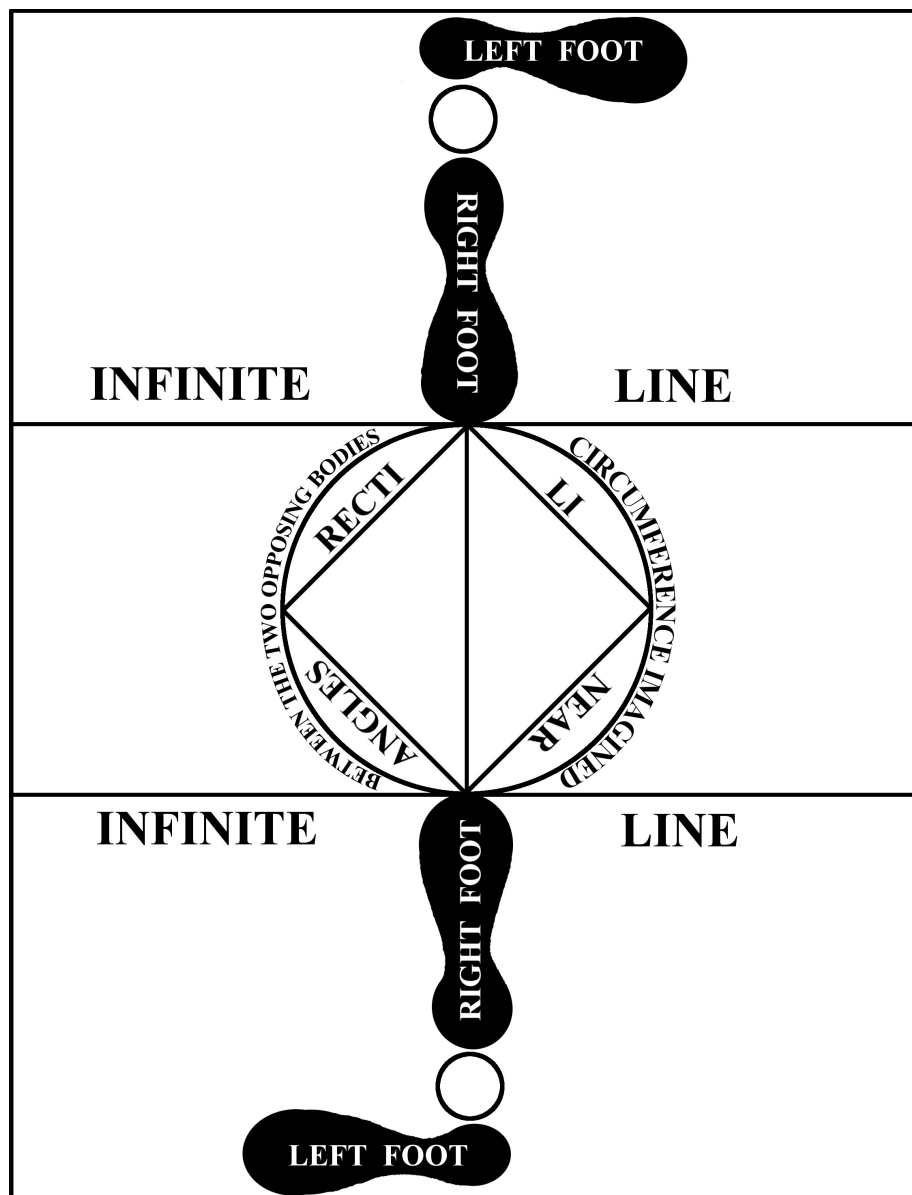

**T**HE wise craftsman that takes charge of making some edifice, so that it is perfect, firm, and durable, places utmost care in taking the foundations of the depth and bowels of the earth. With utmost diligence, with ruler and other instruments, they seek to make them straight and not inclined to any side.

Thus, for this edifice of *destreza*, wall and fortification of the defense of a person, it is necessary that when one will exercise it, the principal foundation of the feet is perfect, so that it doesn't lack because of it. For this, you have to take note that the *destreza* doesn't obligate anyone to make impertinent extremes with the feet, such as inconsiderately parting one leg from the other so that there is a great distance from one foot to the other. Many have been given to (and even erred in) this, appearing to them that by opening the legs and extending the body, they reach more with the sword; in this, they are knowingly deceived, as we will say ahead in its place. The harm or danger that can happen will be considered in this form: being in this extreme with the legs disproportionately open, if your opponent wanted to form a straight blow of thrust, or circular blow of *tajo*, to which it was necessary to delay that movement or wound them at the beginning of it, having to make use of one of the angles (that will also be declared in their place) that they are, having to be with an almost incomprehensible speed, you will not be able to do it. This is because if you have to graduate<sup>55</sup> forward, or as is commonly said, give a step, you necessarily have to bring in the left foot, which will be so parted from the right, so that it supports your body, in order to be able to lift the right. So as Aristotle says, any movement, by man as well as irrational animal, consists of rest and work in this manner: so that the right foot can be lifted high, the left has to be stopped, on which the body is supported, and vice versa.

Aristotle.  
Walking and  
running  
consists of rest  
and work.

We commonly see in walking that when the foot is lifted, it is because the other is already set down and supporting the body on itself, which is what the other had done, and no other way. It will be the same if it would be necessary to degrade<sup>56</sup> backward; it would be necessary to lift the right foot and bring it close to the left, which is parted, before it can be lifted. The reason why people have not been given to this is because they have not seen this manner of walking, and what they have used is that, being established<sup>57</sup> (even in said extreme), if it is necessary for them to degrade a step, they do no more than taking the right foot back, the left foot remaining ahead. If they want to graduate forward, they put in the left foot, leaving the right behind, which is seen in the entries that they make of the steps; how harmful this is will be said later. Returning to our purpose, being in this extreme, the movement that you will make will be so slow and spacious that it harms you by being in said posture. Geronimo de Carranza, in the declaration of his book, calls this a tiresome posture, by participating in that extreme, and not having any that is not harmful, except those that the *diestro* makes in the cases that are offered, which serve to offend the opponent and be defended from them, as you will see in the discourse of this book. In resolution, know that the best posture, and where the body is most rested and disposed to come to any movement, is the feet close in good proportion, with the right placed ahead, pointed straight to the opponent's body, and the left close to it, not straight like the first, but across such that one heel comes to be in front of the other, parted the full length of an ordinary span<sup>58</sup> of a person, no more, no less.

Carranza,  
folio 2.

---

56 *desgraduar*

57 *afirmado*

58 *geme* – the length between the tips of the outstretched thumb and index finger, about half a foot

The *diestro* takes note of what is important.

Simile against those that establish themselves with the feet open.

If the feet were together, it would be perpendicular, and one would be able to make you fall to the floor with little strength, which you will be able to experience. In our posture, the body is rested, which is what our author calls the posture of proportion, because the body is over both feet equally, as shown in our demonstration, which you have to understand in this manner. The small circle that is between the right and left feet is the distance of a span that one has to have from one to the other, as we said. The larger circle that is between the right foot of one, and the right of the other, is the distance from one opponent to the other. It is an infallible rule, that never has any exception, that in *destreza*, at any time, for any blow, in any state and point that you will be found, it has to be with this same proportion of feet. Any time this will be lacking, it will be very harmful to you; the same has to be understood when the left foot will be put in, because then it will serve as the right, and the right as the left, and these will be exchanged, but with the same proportion. It will be of little importance that one is established with their sword, making whichever diligence to wound or be defended, if the principal fundamental, which are the feet, are disproportionately open, as all have them. This is similar to the statue of Nebuchadnezzar, having a head of gold, chest and arms of silver, abdomen and thighs of bronze, legs of iron with the feet partially clay,<sup>59</sup> or how other edifices of great stones, whose height is great, with the foundation made of adobe and clay, are fragile.

---

59 Book of Daniel, chapter 2

In this manner, although you have a head of gold in knowing many blows or techniques, and chest and arms of silver in spirit and strength, and abdomen and thighs of bronze in strength of limbs, and legs of iron in the suffering, if you have feet of partial clay fragile from some extreme of that said, neither will you reach victory, nor go without danger, because the slowness in such cases brings that with it. We will be able to bring many examples that the posture that we said is the most certain and advantageous, but you can be satisfied with a few. Since I remit experience to you as a good master, it will remove the doubts you will have. Consider when you are in a circle of conversation, how you have your feet or how the others have theirs, and you will find them without any care, placed as the demonstration shows, not with the legs open like a bridge. Also consider when one wants to run, if they have the legs open and the feet disproportionate, and you will see that they have them together. For proof, place yourself in the extreme that I say, the legs open, and you will see that the little that you are in such extreme you will not be able to suffer it, and you would be in the posture that I say all day. We also see that one who runs, jumps, throws the bar, plays ball, dances, flees, attacks, stands, or walks, all have their feet proportionately open, without much danger; one who exercises the arms has them so open, which is the cause of their death. As these examples are certain, I don't want to bring others that I could, but since we deal with this material, we will remove an error that some have given by saying that the left foot can be put in at any time, as they are accustomed to in the entrances and passes that they do. Putting in the left foot and then the right is more impertinence than advantage, as is said, which will harm one who does it without time and in important cases, because when the *diestro* puts in the left foot, it is more to offend than be defended or play, as Carranza says in the third dialog.

Examples for those that establish themselves with the feet disproportionately open.

Carranza, fol.  
165

Aristotle.  
The movement  
of any animal  
begins on the  
right side.

However, this is by means of some of their and their opponent's movements, or by means of having the sword subjected, as you will know ahead. But to those who say that it is advantageous to put in the left foot, we have to be convinced by the authority of Aristotle, that the movement of a person, or any animal, begins and has its origin on the right side, and that is the first that is moved in all. There are also many examples of this in one who runs, as we said, and in one who walks, who always begin with the right foot, because this movement is natural in all. We conclude that just as the right foot is what we move first to go forward, it has to be the left to go backward, without forcing anyone to do the opposite. Just as graduating forward with the right, the left then has to follow, being placed in the same proportion, when it will be necessary for the left to degrade backward, the right follows, being placed close to it, as seen in the demonstration. The definition of this point has to be that going forward, the right takes charge and the left follows, only being placed close to it, but going backward, the left is the one that governs and begins the movement, and the right then accompanies it, being placed close to it, as said. This is such that, farther from or closer to the opponent, the right always has to be ahead, except in the cases that are to wound with the left, which then it serves as the right, as is said. The rest that lacks close to the body will be seen in the following demonstration.

The integrity that the  
diestro has to have in  
the limbs when they  
establish themselves.

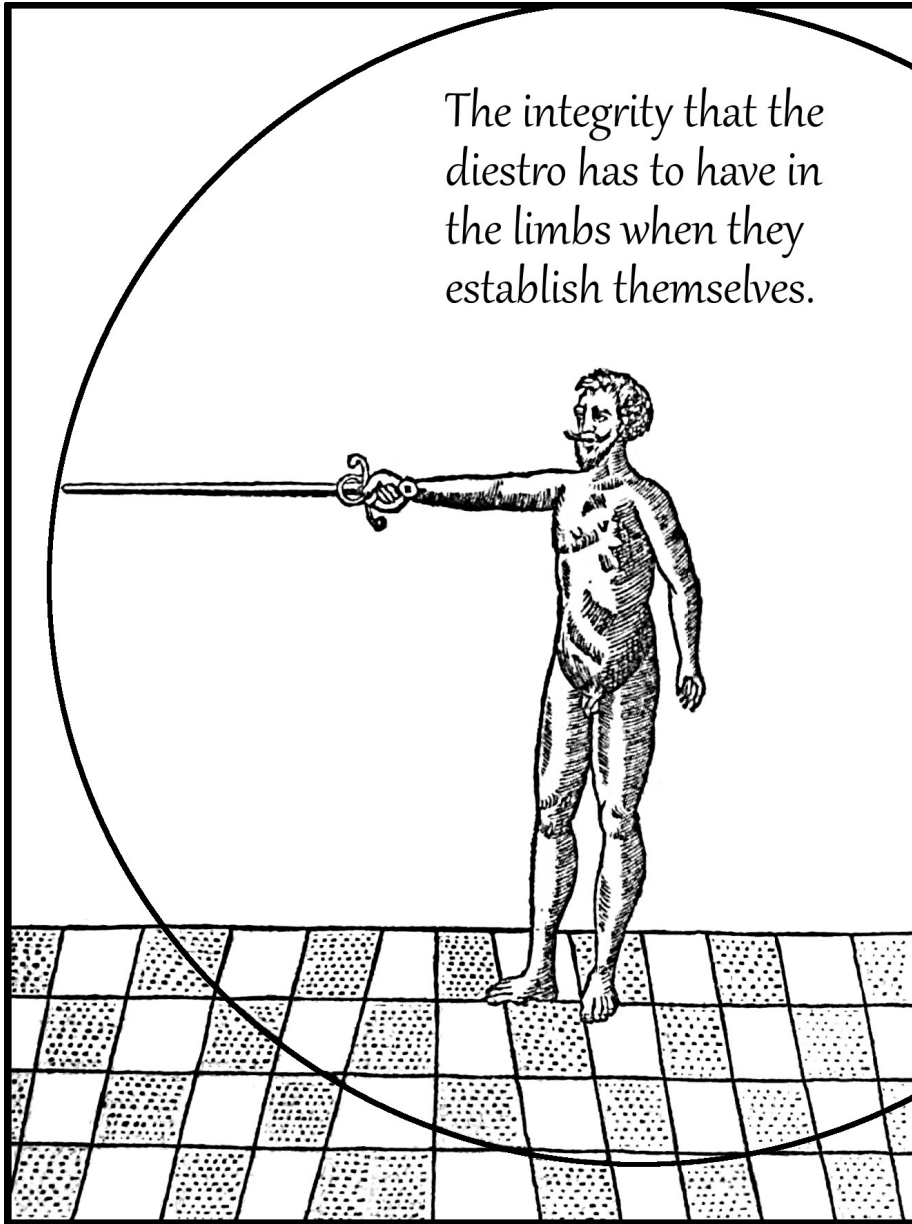



How the diestro has to  
exercise the arms  
without removing the  
cloak, sword, or dagger.

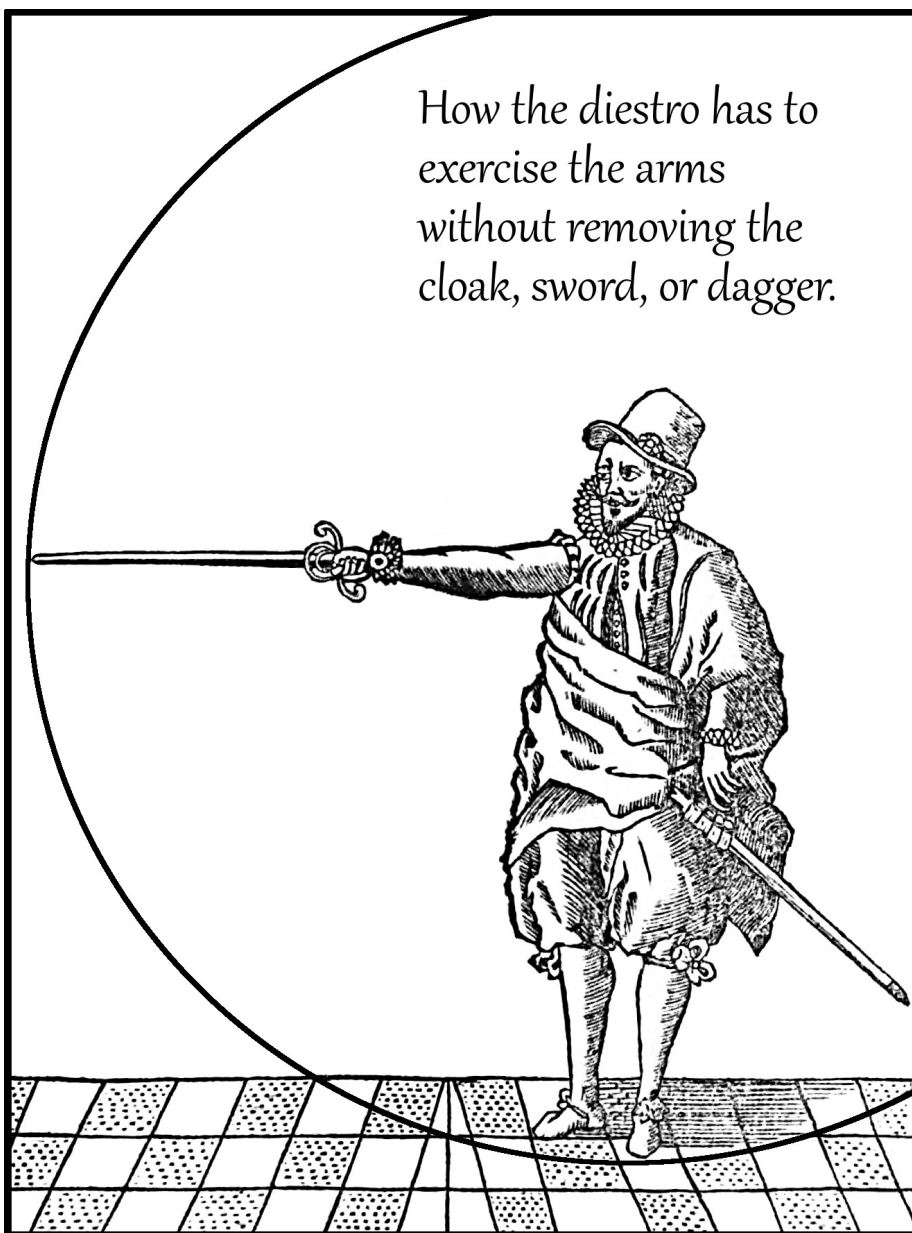



**P**LINY, in his natural history, considering on one hand the baseness and rusticity of irrational animals, and the greatness of understanding being denied them, esteems them little, and on the other, seeing the infinite nature with which they search for their advantage, flee from their harm, and seek their conservation, admires and is amazed. Placing the consideration in man, to whom a part of the celestial treasure was given, enriching the soul with three very fine stones, which are the potencies that produce and engender free will, these had to bring well-known advantages to the other animals. Seeing that in many things it is the opposite, he reprehends it, saying that there had to be great confusion and shame in seeing that another animal knows what is harmful or advantageous to it, and one just ignores it, which results in their harm. In this he is knowingly right; it can be neither denied nor contradicted for many reasons, and in particular in the matter that we deal with, the proof of it will be enough. Aristotle, in the second on the elements of animals, says that among all those, only man walks upright and erect, because their nature and substance are divine and celestial, which suited them more than any other animal. Aristotle proved it in his seventh book of Physics, saying that man is a lesser world in comparison to this great world, that contains all things in itself. Because of this, man is lord of all animals, which obey and are subject; thus it was convenient that a more perfect thing, as man is, was given a more perfect figure and movement of it, which is done high, where perfection is.

Pliny, Natural History.

Aristotle, 2, on the elements of animals.

Why man walks erect, and no other animal does.

Aristotle, Physics, book 7.

The harmful  
extremes that  
those who deal  
with the false  
*destreza* put  
themselves in.

Because a figure convenient to their movement is appropriated to each thing, a diametrical figure counterposed upright over the feet is particularly suited for the things that have two feet, which are foundations of the whole body, like the foundations of houses and edifices. Although other serious authors give reasons that affirm and accredit this, it is enough to give this charge to the professor of arms, as one will not easily leave from it. When some disciple will give their part, at one point we will catch them red-handed, as is seen when they are exercised with the sword, as they inconsiderately discompose their body, being placed in a thousand very harmful extremes, whether leaning over the left foot, or over the right, or bringing the feet so close together that one is placed over the other, without ever having rest or repose, perverting in all the natural order of movements. However ugly and harmful it is, it is necessary that we look to the examples, because of them being many and having great strength to bring a person to good or bad. There are none that doubt it, and many times even the easiest and most homely have the most strength to persuade, because understanding receives them better. We will consider whether one (healthy in their limbs) of good disposition of body, and gallant, walking around, stopped going like other people, the body erect, moving foot and hand with gallantry and moderated acceleration, bearing oneself as ordinary among the gallant. Instead they wanted to go waddling club-footed like a hunchback, or with the body so inclined that the face was close to the floor, or the opposite, or taking a step so long that it was laborious or sometimes even impossible to return to join the feet to give another step.

As we have said in another part, in the opinion of Aristotle, the movement of walking consists of rest and work; what would be said of that? It seems to me that there would be no one who wouldn't laugh and make jokes. If an edifice, after the careful and diligent craftsman had worked straight in all perfection, was crooked or twisted, at that point we would say that it would want to fall and wouldn't last. Nature formed man so perfect in all its limbs, with such concert and odd composure that understanding cannot consider it perfectly, and the most outstanding admires and is amazed. So if one does not esteem it and falls to some of the referred vices, we will be able to say that it doesn't deserve the possible disgrace that can come to it, or the danger that could be imagined to harm it. With the desire that reason obligates me to ensure that you are free from all those, I decided to place this demonstration here, for this principal cause as well as to advise the advantage that results in having the body erect, so that its profile is good (which is one of the fundamentals of greatest consideration in *destreza*). The arm also has to be straight, and advantages result from it, for one's own defense as well as offending the opponent, and being able to attend to their movements with less work and more freely. It better conserves breath, from whose conservation not only proceeds victory, but the conservation of life, whose importance is left to consider (which we will deal with in particular in a preparation that has to be done to enter into the universal).

Very important part to reach victory.

Three advantages that result from having the arm straight.

On the way, it manifests how the sword has to be taken, and why it has to be gripped in the hand, and the advantage that comes from it, and those that result in having the arm straight, which are three, all very important: reaching more to the opponent, having more strength in it, and the last, being free from a blow that they give to the elbow in the false *destreza*. They seek this with as much truth and diligence as one that they usually give to the foot, but that of the elbow they celebrate as an artful and secret blow. They find themselves content and victorious when they have reached the end of their pretension (which is giving it in the elbow). However, the one and the other and all the rest will cease without them achieving their intent, by only keeping in all to the straightness and integrity that the demonstration and figure of the man shows.

As important as it is to have the body proportionately erect, not many appreciations are needed, nor is there much difficulty in understanding it. In the first demonstration of the feet, what we deal with would be enough, but you have to take note that not only do the feet have to be proportionately together as we have referred, but it is required that the body also makes use of such proportion. In this, one complies with what our author calls moderate angle, which is being over both feet equally, because this is the best. If it was in the extreme of the feet together, we have already said that it would be perpendicular, which is the same that Carranza called being in line, because in the posture of the feet together, the whole body makes a straight perpendicular line from the head to the feet.

Carranza, f. 166.

Carranza, f. 166.

It will not be steady, due to lacking the moderate angle of the legs, as according to our author, such angle is where strength is, by having that proportionate distance from one foot to the other, which is where a person can better and more promptly reach their opponent. Being in this way will end the enigma that Geronimo de Carranza places to mathematicians, saying how can it be, given two lines, one greater than the other, that without increasing the quantity of the lesser, it is made to reach more than the greater (without diminishing its length). This is done with only the one who has the greater line establishing themselves in the extreme of the feet disproportionately open, and the one with the short established in moderate angle with the feet proportionately together. If both were established the same way, either in equal proportion or in equal extreme, the greater line would reach more. When they were equal, the reach would be equal, because as we have said, one equal to another cannot have power, and thus the shorter reaches more than the longer, due to the latter being established with it in some of the extremes, and the one with the shorter being established erect.

You also have to take note that aside from having the body erect, as is said, it is very important that it is profiled, such that the chest is not directly to the opponent's sword. Besides not having the promptness to impede the movements that the opponent will make, one will be reached less with the sword (as will be proven by demonstration). As such, the conclusion is that in order for the body to be in good profile, whether it is considered with sword or without, it has to be sideways, as manifest in the demonstration.

Solution to the enigma that Carranza posed to the mathematicians, fol. 166.

The profile that the body has to have in order to be good.

Carranza, f. 2,  
in the  
declaration.

Whether the steps are on either side of the circumference, or on the line of the diameter, or on whichever of the collaterals, which are the lines that form angles, always keep to this precept, because going against it would be done with notable harm. When it would be important to make use of the step of the left foot, as we said in the demonstration of the feet, it serves as the right. Since it has to be ahead and the right behind, one has to keep the same punctuality that the left side is profiled and the chest is never straight to the opponent, except in some propositions or techniques that go above the sword, putting in the left foot; in such case there is no place to be completely profiled. But it has to be understood that this has to be worked by means of having the sword subjected, and in no other manner. Because our author says that the profile touches the figure of the body, without the sword being able to work. He also says that the profile is the good or bad figure of a body, so that we come to verify with certainty how a person profiled reaches more than another who is not. Believing that it would be convenient to convince any understanding, I wanted to place it and prove it by demonstration, so that you understand it with less work, and in one point you know the good or bad profile that your opponent will have, and you know how to gain the degrees of it, as such an important thing. At the same time, I wanted to warn about some extremes (as bad as they are harmful) in which the professors of the false *destreza* place themselves, with the desire that all consider it, some leave the bad, all generally know the good, and you and they take advantage, since this is knowingly my desire. All will be able to be considered in the two following demonstrations.

## Line of contingency

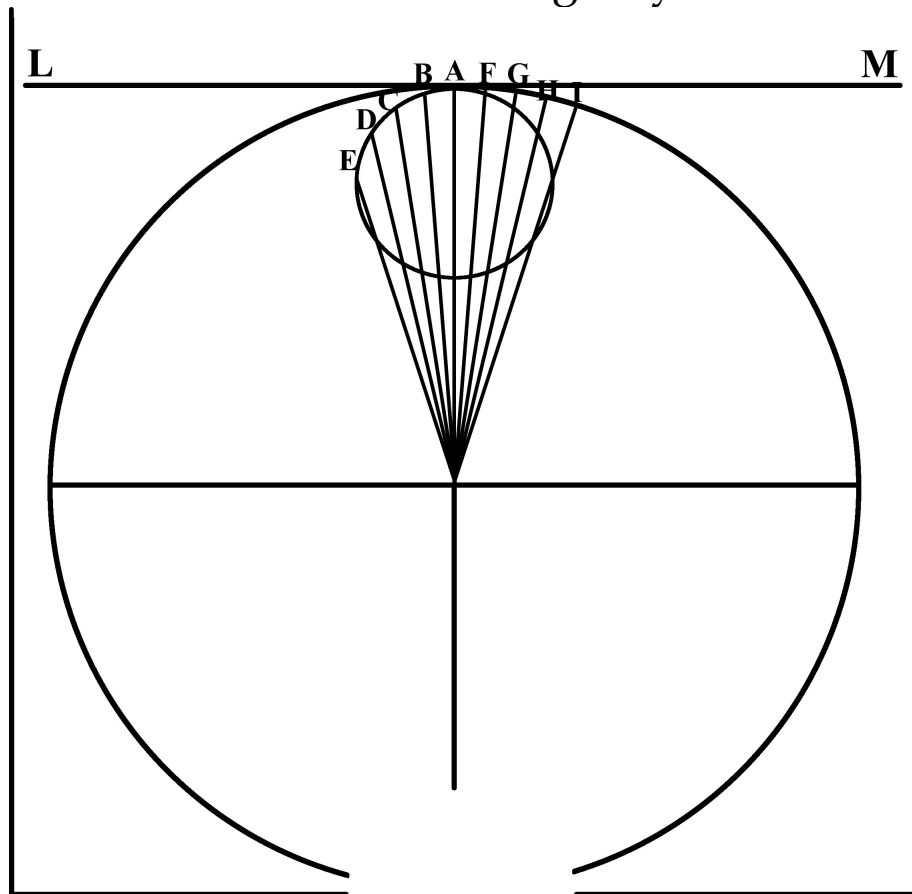

Demonstration  
to know in  
which posture  
one reaches  
more.

**E**UCLID says that a point is taken outside of a circle, which we call D, and straight lines went from it to the circle, and some of them passed through the center of the circle, and others in whichever manner that they are. Of those that will fall on the concave circumference (which is the line that forms the circle, which we call circumference), the greatest of them will be the one that will pass through the center (which we call the diameter), which is where the sword is, and the others closest to it, as seen in the line to point A being the greatest.

Euclid, book 3,  
theorem 10,  
proposition 11.

This is due to said reason of passing through the center, coming to the line of touching, or contingency, which is line LM. Dealing with the left side, we will see that the line to point B is greater than what point C shows, and lesser than the first. The line to point C is greater than the line to point D and lesser than the second. The line to point E is least of all, as seen in the separation that each one has from the line of contingency. But if we now wanted to supplement each one of these four lines and add what it lacks in order to reach the line of contingency, which is the touch of all, like the line to point A reaches. We will see that the line that point F shows, which is what was equal to point B, comes to be greater than the diameter, for all that distance that there is from the concave circumference of the greater circle to the line of contingency. Successively, the line to point G, which was less than point F, to which we add, comes to be greater than not it, since as is seen, there is more distance to the line of touching. In the same manner, the line to point H is greater than what G shows, and the I greater than the H. Thus, what is usually greater will come to be lesser, and the lesser greater. From this, one comes to infer and clear up that for all the other lines except point A (which is that of the diameter), if we want them to reach the line of contingency, it has to be by adding to them the lack that each one has. The solution of this point will be declared in the following demonstration.

Line of contingency, or touching. *Euclid.*

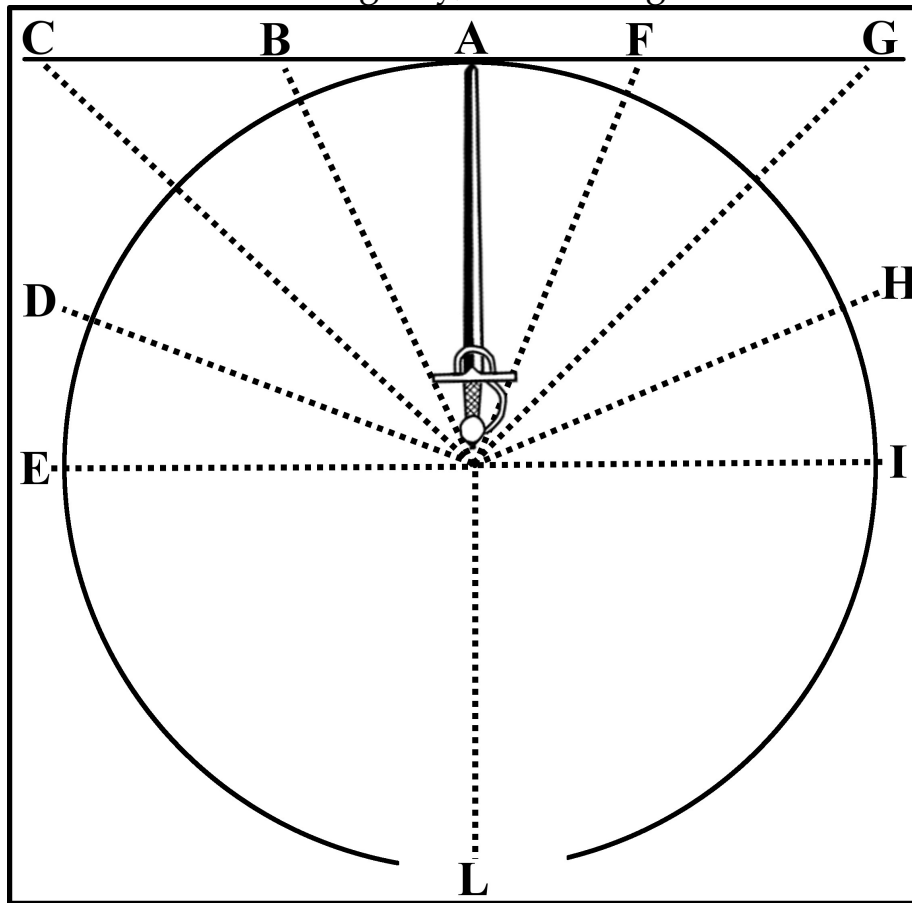

Demonstration  
in order to  
know in what  
posture one  
reaches more.

**W**E accredit this demonstration with the presupposed in the demonstration before this, and what we demonstrated, that the right angle reaches more than any other, and we will have no doubt of its certainty. But for the comprehension of what we deal with, you have to suppose that man, aside from being spherical as we have said, will also be considered in two lines. The one from the head to the feet is called perpendicular according to Euclid, or vertical line according to astronomers. Another is considered in having the arms open, from the one to the other, which we call line of contingency, or touching, according to Euclid, or horizontal to the first (which is from the head to the feet) according to astronomers.

We already spoke in the demonstration of the judgment made of the three angles and which reached more. We will only deal with the one considered from one arm to the other, passing through the chest, by being more to the purpose that we deal with. For testimony, they brought these two demonstrations and their arguments, only for those who can or do understand Euclid. For the rest, the application is what pertains to them, and even that which gives them greater pleasure, by being for those of more facility.

The line from point A to point L, where the sword is, is the perpendicular, and the line from point C to point G is that made by the open arms. If lines are drawn from one point, that which will pass on the diameter is known to reach most. Now it has to be understood that, one established upright with the body profiled, which is how we have said and demonstrated, placed sideways, and the arm with the sword on edge,<sup>60</sup> will reach to point A, which is the opponent's chest. If one wanted to reach to point B, which will be close to the origin of the right arm (which is the shoulder), not making a movement of the feet, it will lack all that there is from the circumference to the line where they go to touch. If they wanted to reach to point C, which will be the joint of the elbow, they will fail to reach by all that which the demonstration shows. If they came to point D, which will be the hilt of the sword, they will not be able to reach it, nor even with another such length of the sword. If one will be established in point E, they will come to be in the parallel line, equidistant, as C E shows, whose nature is that in proceeding infinitely, they never meet.

---

60 *de filo*

The same can be considered in the other lines on the right side, from which we come to make it clear that just as in lowering the sword is parted from the center, which is where it reached on the line of the diameter, and is placed in a part where it is impossible to reach, that also parting it to the right or left side will stop it from reaching, according to what the lines that leave from the center show. Now you have to consider that it seems that they do it intentionally maliciously, or from crass ignorance, as in the case of parting from the central line (which is where the sword is, as said) and removing the arm from its place, putting it in one of the extremes of nails-down or nails-up, is bad and dangerous. They would neither study another thing nor do it, as ordinarily seen in having left said line that passes through the center without dealing with it, as if the act of truth was a bad and harmful thing. They establish in the line of point B, nails-down, arm bent, all in angles, which they say is their technique of the occasion that they give to the opponent. I certainly believe it, because one that does so gives a very suitable occasion to be killed, because parting the sword from the line or point of touching (which is the chest) and curving the arm, it is so, except bringing it to a place that would reach less even if they had the arm straight, as the demonstration shows. On the contrary, the other sword will reach more, and with little diligence, one will be able to wound those who establish in this way, as will be given in its place.

Note.

Note.

What the vulgar call occasion.

What technique is done in point C.

There are others that establish such that they come to point C with their sword, nails-up, as we have said, and there they do a technique whose name is inviting,<sup>61</sup> making a gentle movement, nails-up, uncovering the chest, so that their opponent is inclined to wound them in it. At this point they part the sword more and give space so that the opponent can offend them with a small movement, as we will advise ahead.

The technique that is done in point D.

Others discompose with more liberty, throwing a *tajo*, not very long, bringing the sword to their left side, with the greatest caution and prevention. When the opponent wants to wound them in the chest (which they could, having convenient means, as their sword comes to point D), they catch it making a cross, putting in the foot, giving a very strong thrust. Their oversight of such is known, and the danger is certain. If you will always have caution in choosing the mean of proportion, when the opponent will want to make such movement, you will wound them due to the long voyage that their sword has to make in making the *tajo*, which is composed of offline lateral movement with participation of the acute angle, as well as the brief path that yours will have to travel, since it has to be a forward movement<sup>62</sup> by the right angle, and his sword reaching so little, as the line to point D shows. You will wound them by making use of the circumference on your left-hand side at the point that they make the offline lateral movement. However, if they returned to catch your sword, it will be necessary to free it below, making use of the other side of the circumference and wounding, as will all be advised in its place.

Note.

---

61 *llamar*

62 *movimiento accidental*

Inconsiderately, without any reason or prudence, other times they throw a *tajo*, which they call ripping,<sup>63</sup> applying such force that they bring the sword to point E. For this, the arm crosses the chest, with the same intent as in the half *tajo*,<sup>64</sup> of returning to catch the sword, and coming to such point, it will be in the equidistant parallel line, as has been said and seen. With this, having the sword so remote, and the voyage that it has to make to return to the right angle that it left being so long, and you being established straight and having chosen said mean of proportion, and the movement being so brief, as we have already referred, one can consider how easily they will be offended, even before the offline lateral movement finishes, by only using a little of the circumference on your left-hand side. If they will return to catch your sword, which is the intent with which they throw the *tajo*, considering that theirs comes to the obtuse angle, you will pass with a curved step on the other side of the circumference, freeing the sword below, wounding in the chest, as we have advised in the point before this, and we will demonstrate ahead.

The technique that is done in point E.

Discussing the other four lines on the right side, even though for declaration of the profiles and reach it will not be necessary to declare them, as they are similar to the first, by declaring the technique that is done in each one, some of them will be told, which is not long-winded to always say what suits. For the first, point F is a technique that is done by bending the arm so that the quillons of the sword comes to be in front of the shoulder, uncovering the chest a little, which they call inviting<sup>65</sup> the opponent to wound in the uncovered chest.

The technique that is done in point F.

---

63 *rompido*

64 *medio tajo*

65 *convidar*

I decline this reason or invitation, but the cost of the invitation will be at their expense, if you had chosen the mean of proportion, as with it, aside from reaching more, the movement will be brief; passing a little to the circumference on your right-hand side, you will wound in the chest. When they want to catch your sword in their quillons (which is that they intend), the blow will have already arrived, and you will be able to return to the mean of proportion, where you will have safety and liberty to return to wound.

The line to point G, and the technique that is done in it.

The line to point G is so frequented by them that they almost believe it to be the end of their defense, and many times when they take the sword, they do nothing else. In it, they make one of the most memorable techniques which is also called *inviting*, like that of point C, as both movements are the same size (each on its side). In this, they uncover the chest, so that one would wound them in it, with the intent to beat the sword and give a *tajo* in the head. They don't look at whether the movement that they have to make to achieve their intent is lengthy or brief. If the opponent's is quicker, they will be able to wound, like you will wound them, having chosen the mean of proportion at the point that they would open themselves or uncover their chest, by only giving a step on the circumference to your right-hand side. With this, you will gain the degrees of the profile, which is enough to be able to wound them with your sword, without theirs being able to reach unless they give another step to establish again; at the beginning of that, one will also be able to wound them.

The technique that is done in point H.

They form the *reves* in the line to point H when they finish the *tajo* that we advised in the line to point E, with the same intent to beat it to give a *tajo*, with said prevention of the mean of proportion.

Considering that aside from having the sword so remote, as the demonstration shows, they form said *reves* with participation of the acute angle, against which the right will reach more, and you will be able to wound them. If in working, it would be with brevity, making use a little of the circumference on your right-hand side, so that the sword remains remote on your left side; we will advise the rest that is lacking in its place.

If they came to point I, although not generally, sometimes they place themselves in it, uncovering the whole chest. They would come to be in parallel lines, without hoping to be able to wound from there, because of it being impossible. If one who would do such has some notion of being defended, it disillusiones them, because it will be impossible if the *diestro* will have chosen the mean of proportion, already referred, because with it, one will be able to wound them with a movement so brief that it will be almost incomprehensible. If one has doubt that they can comprehend it much, much greater doubt will be had that they can prevent it with the remedy, as in reality they are so far, however close they desire. But, you have to consider the demonstration and figure of this man, which is on the rectitude and integrity of the arm, to be a new thing, the language and doctrine rarely seen, and when seen, not kept; the reason has to be ignoring the advantages that result from it. There are two that both enclose the desire of man, which is to offend the opponent and remain without offense. Having the arm straight, one can attend to the opponent's movements, impeding the thrusts and wounding at the same time, and the *tajos* along with the *reveses* and *mandobles*,<sup>66</sup> defeating them without parry, not only wounding sometimes at the beginning of the violent movement, and others at the end of the natural. In this, the feet will supplement what will be missing for being reduced to proportion, with steps on the sides of the circumference, as will be manifested in the demonstrations ahead.

Point I

The advantages that result from having the arm straight.

---

66 Cuts delivered by moving only the wrist.

Why the blow  
is given in the  
elbow.

We come now to declare a blow that they seek to give in the elbow, as we promise to manifest its remedy, and the reason why they do and can give it there among them. It is that they establish themselves curved, bending the arm at the elbow, and the sword necessarily has to rise to the obtuse angle; in this, they find the elbow uncovered and like to wound in it. There have been some so skilled in this blow that sometimes they have disabled the opponent's arm. But as the philosopher says, ceasing the cause ceases the effect, and as establishing straight extends the arm, without making angle or any bend in the elbow, they will not find a place to wound. Of course when it is straight and they seek it, or will seek to give it, it is and will be to their detriment. As they make a half circular movement and incline the body in order to reach, and the right angle reaches more, as we have proven, then without the *diestro* making any diligence, they are wounded with as much rigor as they place in wounding. With this, in order to be defended and wound them, no more is necessary than being established in right angle.

Aristotle.

Remedy  
against the  
blow to the  
elbow.

How the  
sword has to  
be taken.

Now it remains to advise the manner of taking the sword; although it seems that you will know it due to the common use there is in taking it, when the reasons that I will give are heard, it will be possible for you to be found so deceived that you take the work of reading them as well employed. Even though for this, I could remit to you the book of our author, as in the dialog of the philosophy teaches by demonstration, how it has to be taken, I want to take on the work of translating it, adding something more for its declaration.

Carranza, fol.  
178.

The ordinary and common use of taking the sword has been placing the finger that we call thumb (which is the first on the hand) above the *recazo*<sup>67</sup> of the sword. This oversight has happened many times to knock it from the hand, by being in a bad posture as well as the manner of taking it, without dealing with the rest, as all is manifest with the one. The demonstration of the man demonstrates this well, which appears to have the sword in this way: the index finger, which is second on the hand, has gripped the quillons by the junction that its arms make, and the thumb above all four, closing and gripping the hand with all the virtue that the tendons, muscles, and sinews have. Placing the thumb above the other four is of no little consideration, as our author proves very elegantly that one only has as much strength as the other four. This being proven, seeing that when we want to make force with the hand, throwing or gripping anything, then we come with the thumb to favor the other four, because we feel them weaken easily. Also, when one makes a wager that they will not open the hand, it's not with the thumb lifted, but with it gripping the others, as the key and lock of all of them. Finally, in every thing where one wants to make force with the hand, the thumb is what strengthens it, gathering the rest below themselves as support for all, as everyone will be able to consider in their own hand. Many times it has been seen in taking the sword as it is vulgarly taken, and in it being subjected, communicating some force, the four fingers alone not being able to resist it, nor having the sword and then coming with the thumb to favor them.

Carranza, fol.  
155.

Why the hand  
has to grip  
with the  
thumb.

---

67 The unsharpened part of the blade near the hilt.

Note.

Since you trust in me, and I in Geronimo de Carranza, and he in long and certain experience, believe that it is the best manner, strongest and most secure, so that it is not knocked out of your hand, as well as to be able to better attend to the opponent's movements. Those that you will decide to do are the quickest, because however much more the sword will be gripped in the hand, the virtue of strength will be communicated more forcefully, with which you will better be able to defend yourself.

The advantage that results from gripping the sword in the hand.

Aside from this, a point of great importance for your defense results from here, which will be that touch is more certain and known. It is a precept so important that by being such, a particular manifestation of it will be done, by means of which, you will be able to be defended and offend. The last and most

The advantage that results from having the body erect.

important advantage that proceeds from having the body as we advised, is the conservation of breath, which is known, and reason manifests it, which is of such importance to all people, in particular to those that profess arms, in which the movements

The harm that comes from accelerated movements.

are more accelerated, quick, and sudden. This many times results in exhaustion, and exhaustion results in fear, shock, weakness, and from all this, loss of confidence of reaching victory. In the brief time that they battle, they are out of breath and choke, because as they always place the body in some of the extremes (that we have already said), and the most used is being extended and spreading the feet much.

Note.

At the point that they need to give a step, whether to offend the opponent or to defer some movement that they do by gaining the time that is spent on making the first movement, which is being reduced to the moderate angle, and so that they don't miss their intent, the body has to be moved with greater velocity. As has already been said and is well known, all movement is the cause of heat, which will be more if it would be more accelerated, and while more movements would make the natural heat have more heat and more necessity for fresh air to be conserved, without burning up completely. Thus it is seen that when they are exercised, as they go in continuous movements, so afflicted and breathless in the little time that they battle, they tire, sweat, and choke. It is necessary to forsake the sword, because of the movements that are done (having the body in some of the extremes) being great work, it follows that one who will make less movements will tire less, and one who makes more, more, as is ordinarily seen that one who walks is less tired than one who runs and jumps, or does another quick exercise. On the contrary, in having the body erect, it is disposed to attend to one's determinations, to serve the understanding, and will, with more promptness, and to impede the opponents movements, making them so calm, without receiving any tiredness or work. There is no doubt that one is more tired in an hour of exercise of running, jumping, or bar throwing, than in walking six, and it better conserves the breath, by some movements being so haphazard, and the others so tame and calm. Because of the importance of the conservation of breath, a particular point has to be written, due to its importance being particular in which you will see what is missing here.

We have resolved that having the body erect, in moderate angle, results in these and many other advantages that could be manifested, such that we will demonstrate the bad, by coming with certainty in knowledge of the good, because one opposite close to another is known better. The conclusion of this point is understanding that being established as we demonstrate in the figure of the man is better, where the body is profiled and disposed to attend to its defense. Since it is promised how one gains the degrees to the profiles will be manifested in its place, I remit it to you.

Why the nude man was painted.

The first man that we placed nude is in order to demonstrate the integrity that you have to have in the joints of the legs as well as in the arm. It is understood that one reprehends the vice that the vulgars have when they establish or exercise, in bending the right knee, and other times the left, and even sometimes sinking it to the ground, believing it gallant. The right angle that worked their defect would be well employed there, so that they hit their folly and scorn later being placed in similar extreme. All of which you have to avoid as something so harmful, and learn and use what we say and demonstrate, as a thing of such advantage. The one that we place clothed is also to advise you how you have to exercise the arms, without removing your cloak or sword, by being convenient, as will be said when we deal with the exercise that you have to have so that you truly attend the occasions more easily.

Why the clothed one was placed.

Mean of proportion of equal swords,  
very important.

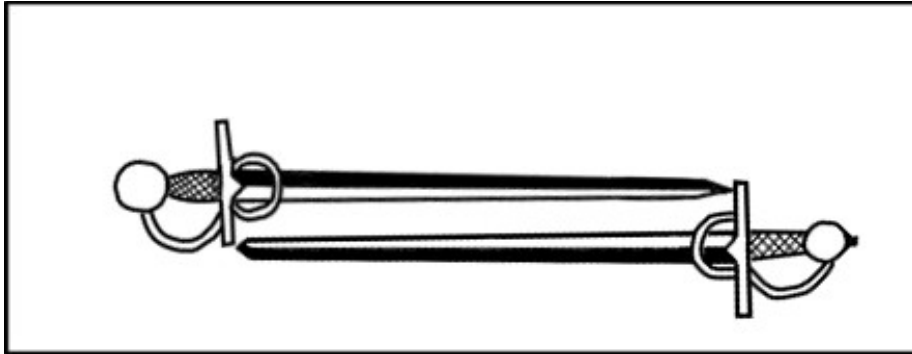

**T**HE significance of these two swords together, equal in quantity and length, is of such importance that it cannot be more so; it is the first thing that you have to do with your opponent, because the good finish of any work has its origin in the beginning. As the philosopher Pittacus says, the half is more than the whole, which is the same as saying that the difficulty of a work is in the beginning and its success, and the particular intent that you have to bring has to be divided in two. The first is recognizing the opponent's sword by means of the mean of proportion (which is the sense of this demonstration), which will consider the length of it, seeking that the opponent's sword does not pass the quillons of yours. In this way, you will comprehend the movement that one will make to give whichever blow, which you will do without difficulty, as there will be such distance from the point of their sword to your body (having your arm extended straight) that it will be impossible to not know it.

Carranza,  
declaration,  
fol. 2

The other, that having chosen such mean of proportion (which is measuring the swords according to Carranza), the opponent will not be able to make a movement, withdrawing back, that you do not also comprehend and even subject, if you will quickly graduate forward as much as they will degrade back. Your step will be equal to theirs, and with more advantages, because one going forward is walking naturally (as we have already said in another place), which is done without any work, but that which is done backward, aside from not being as long, goes with less certainty. What's more, consider that any movement that is done by throwing the foot back is not for wounding (such movement being from the mean of proportion), which will result in you having more space to go forward. This mean of proportion is nothing other than a comparison and certain respect of two quantities of the same type. As Marsilio Ficino says in Plato's *Timaeus*, because an equal quantity is compared and conferred with another equal quantity, this is when the swords are proportionate together or measured in right angle, as the demonstration manifests. The mean of proportion is a convenient place for any cause of *destreza*, to exit or enter with certainty, without passing into the superfluous or lacking what is necessary. Because of this, it is very properly called a mean, lacking all extremes; being placed in it, you will neither be so close to your opponent that they can offend you without you knowing their movement, nor so distant that they, or you, can't be wounded with any small movement.

You can easily impede any movement that they will form, having knowledge of whether they can reach you with such movement or not, by means of the distance they will have from their sword to your body, and the size of one's own movement, which are two of the fundamentals on which *destreza* is founded. As Geronimo de Carranza says, many of the professors of arms have lacked this knowledge, without having consideration of it, but in taking the sword in hand, they inconsiderately come to their opponents. This results in them being wounded, by not knowing what the distance is from body to body, and sword to sword, nor whether they will be able to reach to wound with a small or large movement. It is then the conclusion of this point to know what weapon the opponent carries, and what movements they make, with which parts, and what quality and size, and what species. I say size in the parts of strength that will be communicated, because some of the movements that they make are tepid attacks, without having any effect of wounding; it is also knowing the movements or steps of the feet in order to know the difference that there has to be, which we will deal with in its place. I say species in knowing what genus of blow they will want to form, whether *tajo*, *reves*, or thrust, due to the remedy that has to be applied having to be different for each one. Finally, being sure that without new determination and movement of the opponent, you will not be able to be wounded. This determination has to be very well known; you have to choose said mean of proportion, trusting that from there, if your opponent will want to wound you, they are forced to make a new movement of the foot, body, and arm.

Carranza, folio 27.

The *diestro* notes.

What is size in *destreza*.

What is species in *destreza*.

It will be impossible in any other way, as for example: if a rounded circle was made with a step, with the leg being the point in the center of said circle, and one wanted to make another, greater or lesser, they wouldn't be able to except by changing the step to long or short. From that point, without opening or closing it, if one wanted to make another circle, it would necessarily be on the circumference that was made first, without making another again. Thus, if your sword was in the mean of proportion, however many movements that the opponent makes, if they would not move the foot forward, they could not reach to wound. In making movement, it will be easy to know to delay it or wound, as we will say ahead.

Objection to  
the mean of  
proportion.

Infallible  
solution in  
favor of the  
mean of  
proportion.

Some that have wanted to be witty have said that the mean of proportion is not certain, due to requiring the opponent's company, with them being free lord of their will. They will not consider that the body is the object of the blow, and if the opponent will want to execute it, they necessarily have to pass through the mean in order to have effect, unless it is given in the air. All the arguments and objections cease by understanding that in whichever posture that the opponent will be positioned, high or low, to one side or the other, curved or straight, with a long or short sword, quickly or slowly, that if the body has to receive the blow, this has to be composed of movements, and their sword necessarily has to come to the point of the opponent's, then to the middle and to the end, until coming to the body. Being so, when their sword will come to the place where you had chosen the mean, being stopped, you will do the same as if your will have chosen it, whether by your cause without preceding theirs more than the disposition of waiting, or by means of said effects of the blow. But if one will not want to wound, nor even want to wait, for that, there is no *destreza*, nor will it be necessary, since they flee.

Mean of proportion of the short sword against the long sword.

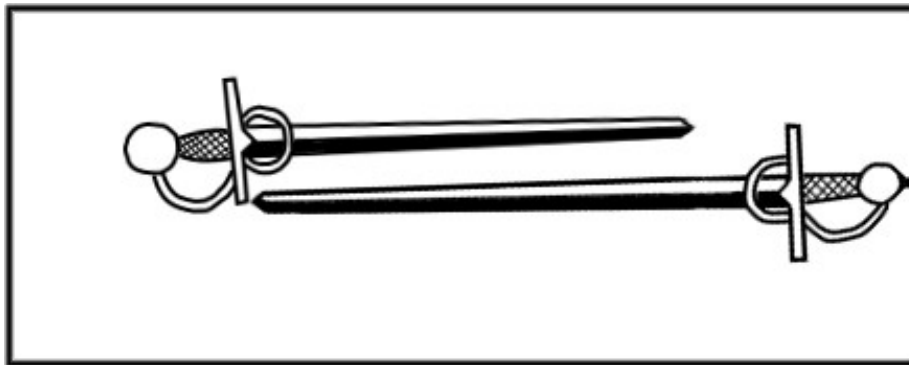

**S**OME people, guided by a false and thoughtless opinion, have taken to carrying swords longer than the mark,<sup>68</sup> thinking that they are safer with them. They have sought to confirm and introduce this opinion as good, having made (or brought to their purpose) an axiom that says a finger of sword, and a palm of spear, is a great advantage.<sup>69</sup> They are right that it is a great advantage; not for them, but for their opponents who will carry short arms, because of how the dagger has great strength in all parts due to the quantity of its length being small. Geronimo de Carranza says that it is all center, because it is closer to the origin of strength, which is the arm; I call it origin for the sword, which Carranza calls the principal center.

Why the dagger has great strength.

<sup>68</sup> Established laws set the mark for maximum blade length (cross to tip) at  $5/4$  vara, which is approximately 41 inches or 104 centimeters.

<sup>69</sup> *dedo* (finger) is a small unit of length, about  $2/3$  inch or 17 millimeters.

*palmo* (palm) is the distance from outstretched thumb to pinky, about 8 inches or 20 centimeters.

Example  
against the  
long sword.

Carranza, fol.  
157.

The intent of  
those who  
carry long  
swords.

Example for  
the long  
sword.

On the contrary, the long sword, as its length is such that is it remote and far from this center, it is weaker, and the movements will also be very weak and easily impeded and knocked down. For example, if we hit a long and thin cane with a short and somewhat thick stick, even though little force would be delivered by such a blow because of the cane being so weak and skinny, due to its length it would drop to the floor, compelled by that small blow. On the other hand, if we hit the stick with the cane, its blow would have no effect, due to the stick being close to the center of its own strength. Since our author, with such firm examples, proved this point in the demonstration of the graduated sword, and experience on his part has proven it, I don't have to be detained in this. I only want to tell, with this demonstration of the long and short sword, the mean that you have to choose if your opponent will have a long sword. Follow the order of the previous demonstration in everything, not allowing the point of the opponent's sword to pass the quillon of yours, for the reasons given before. From there, whichever movement that one does will be well-known as it is easily remedied, due to the sword being so long. The particular intent of those who carry long swords is to throw some terrible punching thrusts<sup>70</sup> from outside. If they were *tajos* or *reveses*, as they are so long, the movements will also be so long that you will have space to offend them without danger. For example, we place a sign in a small wheel that goes around, and in turning it, we will see that because its circumference is small, it quickly passes its course and turn.

---

70 *estocadas de puño*

But if we consider a crane that there usually is where some edifice is erected, and we also place a sign and follow the course of its turn, we will see that it is necessary to wait a long time. As it is so large, even though it goes as quickly as the small, it doesn't conclude its journey and turn with such speed, as appears in the demonstration of the three circles that the arm makes. Thus, although the long sword delivers all the force that it has, with respect to its length, it has to be slow in its circular movements (which are the *tajos* or *reveses*); if they were straight thrusts, they would be weak, as said. If the one with the short sword will enter to the one with the long sword with the speed that will be required, they will not be able to be freed or free the sword, due to its length. But if the one with the long sword would want to enter to the one with the short sword, they will not achieve their intent, because one will easily free it and offend. It is the same as if we will want to throw a spear in a narrow space; it will be impossible due to its length being such, but a sword or dagger can be used with ease, each thing regulated by its quantity. This is enough to understand that it is rather advantageous to carry a short sword, due to the referred advantages as well as not walking as a signified person; it is a superscript that one carries which all read, either that they are arrogant, or that they are nervous or quarrelsome, or that they are of little spirit, as they trust more in the length of their sword than themselves. Finally, if one wants to remove what all the common people look at in someone, they have to flee from all the extremes. As each one is considered as valiant and as spirited as another, there is no reason to carry more advantageous arms than another, because when they defeat someone, they don't leave them justly defeated, but with a well-known advantage, by which the victory would not be esteemed.

Example  
against the  
long sword.

The reasons  
one should not  
carry a long  
sword.

Objection  
against this  
point.

This (as the rest that are written) has not been free from the objections of the envious, in favor of their long swords, being founded in saying, how can carrying them be harmful, since they have two effects: the one, wounding the one with the short sword, with that excess of length that their sword has, and the other being farther from them, by means of the same length.

Solution.

They don't want to consider that the body of a person is where the blows receive the name of the effect by mean of the execution, and where they have to be given so that they are truly wounds.<sup>71</sup> These have to be given with the sword, even though it may be as long as can be considered, it cannot stop until reaching the body. In reaching to the body, which is where they come to lose the force that is delivered, a small impediment may be placed by the one with the short sword, the artifice will be toppled and not wound, and will remain displaced from that lordship that it had in the sword; the one with the short sword will make use of it by means of the movement that they will make with their sword and the step that they will give with their feet. With this, this point is concluded, as it has been proven not only with reasons and examples, but confirmed with enough experience.

---

71 The word *herida* is used to refer to a blow that reaches execution. It has been translated throughout as “blow” rather than its literal meaning of “wound” to avoid confusion. Here, Pacheco explains why the word for wound has been used.

Mean of proportion of the long sword against the short sword.

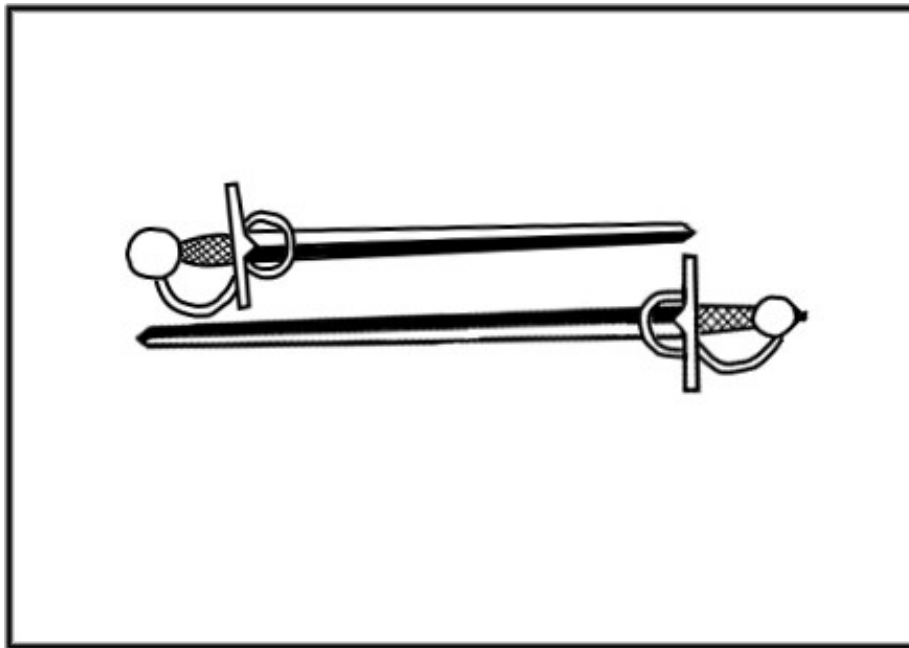

**W**E have knowingly proven in the previous demonstration the deceitful confidence of those that carry long swords, and the danger that they have with them. But the good doctor, even though they see the sick already too far gone and with no hope of recovery, they don't stop applying some remedy, so that when one cannot escape the sickness that they suffer, at least they live a few more days, helping nature. Thus our author, like a good doctor (on this subject), didn't want to make it impossible for one who carried a long sword to be defended, but to apply the remedy so that at least, even though it is not for being completely free from one with the short sword, if they would be *diestro*, are entertained more than being defended, but they will have this remedy.

Note

Because it can happen that you are found with a long sword, or that the opponent's is so short that yours has advantage even though it is only of the mark, it suits you to note that the mean of proportion that you will choose is such that the quillon of your sword comes to the point of your opponent's, and no more, for the reasons that have been said. In this point, if the opponent will not choose a convenient mean for the sword that they will carry, which is shown in the demonstration before this, it will be dangerous, and with a small movement, they will be wounded. As the length of your sword will pass almost to the middle of their arm due to the shortness of theirs, the movement that you will make cannot be easily remedied or even comprehended, because the distance will be so small. This is the point where more see and show the knowledge of the two *diestros*, carrying unequal arms, as each one works to give them the mean of proportion convenient to them. One who will take note of this and seek to know the means of all arms and give that which suits what they carry, whether long or short, will never be wounded. After having chosen their mean, their opponent will not make a movement that they don't know at the beginning and remedy with the inequality of the steps, as we have advised in other parts, and we will advise.

Key and governor of *destreza*.